

Emotron VSC Variable Speed Drive



Instruction manual
English

emotron[®]
DEDICATED DRIVE

Quick Start Guide

This guide is to assist in installing and running the variable speed drive, VSD, to verify that the drive and motor are working properly. Starting, stopping and speed control will be from the keypad. If your application requires external control or special system programming, consult the VSC Instruction Manual supplied with your VSD.

Step 1 Before Starting the VSD

Please review Preface and Safety Precautions of the VSC Instruction Manual. Verify drive was installed in accordance with the procedures as described in VSC Ambient Environment and Installation. If you feel this was abnormal, do not start the drive until qualified personnel have corrected the situation. (Failure to do so could result in serious injury.)

- Check VSD and motor nameplates to determine that they have the same HP and voltage ratings. (Ensure that full load motor amps do not exceed that of the VSD.)
- Remove the terminal cover to expose the motor and power terminals.
 - a. Verify that AC power is wired to L1, L2, and L3 (pages 3-12).
 - b. Verify that motor leads are connected to T1, T2, and T3 (pages 3-12).(The two leads may need to be reversed if motor rotation is not correct.)

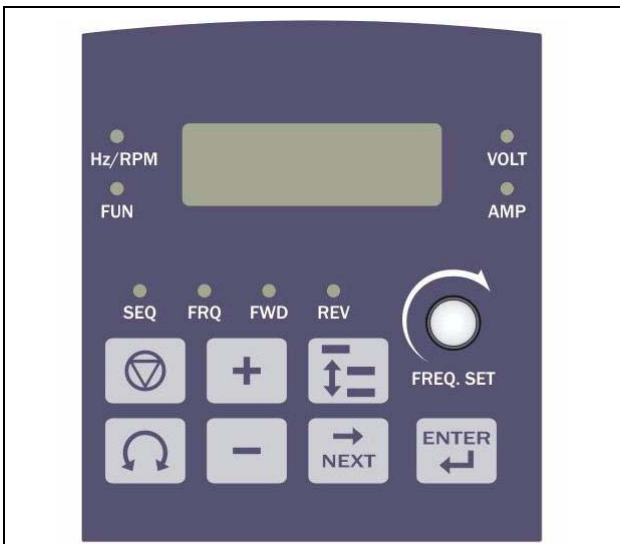

1. **SEQ LED:** 1_00=1, LED Lit.
2. **FRQ LED:** 1_01=1/2/3/4, LED Lit.
3. **FWD LED:** Forward Direction, LED action (Flashes if stopped, stays lit during operation).
4. **REV LED:** Reverse Direction, LED action (Flashes if stopped, Stays lit during operation).

5. **4-action LED:** FUN, Hz/RPM, VOLT and AMP and four 7-segment display, refer to operation instructions for the keypad.



Step 2 Apply Power to the Drive

Apply AC power to the drive and observe operator. Four 7-segment display should read power voltage for 3 to 5 seconds and then read frequency/speed, 05.00. Four 7-segment display and FWD LED should flash all the time.







Step 3 Check Motor Rotation Without Load

- Press the  key (FWD LED should light up); four 7-segment display should run from 00.00 to 05.00.
- Check motor rotation.

If it is not correct:

- Press the  key. Disconnect AC power. Wait for LED charge lamp to extinguish.
- Reverse motor leads T1 and T2. Restart the drive and check new rotation.
- Press the  key to stop the drive.

Step 4 Check Full Speed at 50Hz/60Hz

- Frequency/Speed can be changed by pressing the  or  keys. To move right or left for next digit, press the  key. Press the  key to set the speed.
- Set frequency up to 50Hz/60Hz in accordance with the last rule.
- Press the  key. Check drive acceleration up to full speed.
- Press the  key to stop drive and check deceleration.

Step 5 Other Operations

For information, see VSC Instruction Manual.

Please refer to the following pages:

Set Accel.....	p. 26
Set Decel.....	p. 26
Set Max Speed	p. 26
Set Min Speed.....	p. 26
Set Motor Rated Current.....	p. 23
Set Control Mode (Vector, V/F).....	p. 22

Contents

Preface	3	4.1	Error display and remedying errors.....	73
Safety Precautions	5	4.1.1	Errors which cannot be recovered manually.....	73
1. Mode Definition	7	4.1.2	Errors which can be recovered manually and auto- matically.....	73
2. Ambient Environment and Installation	9	4.1.3	Errors which can be recovered manually but not auto- matically.....	74
2.1 Environment	9	4.1.4	Special conditions.....	75
2.2 Environmental precautions	10	4.1.5	Operation errors	76
2.3 Inflammable materials.....	11	4.2	General troubleshooting.....	77
2.3.1 Wiring notes.....	11	4.3	Quick troubleshooting of VSC.....	78
2.3.2 Applicable specification of magnetic contactor and wires.....	12	4.4	Routine inspection and periodical inspection.....	83
2.4 Specifications	14	4.5	Maintenance and inspection.....	84
2.4.1 Products Individual Specifications.....	14	5. Peripheral Components.....	85	
2.4.2 General Specifications.....	14	5.1	Reactor specification for input side	85
3. Software Index.....	17	5.2	Reactor specification on DC side	85
3.1 Keypad description	17	5.3	Braking unit and braking resistor	85
3.1.1 Keypad display and operation instructions.....	17	5.4	EMC Filter	86
3.1.2 Operating instructions for the keypad	18	5.5	Interface Card.....	86
3.1.3 Operating instructions for the LED keypad	19	5.5.1	RS-485 Interface Card (Model: JNSIF-485).....	86
3.1.4 Keypad operation.....	20	5.5.2	RS-232 Interface Card (Model: JNSIF-232).....	88
3.2 Control mode selection.....	22	5.5.3	Program Copy Unit (Model: JNSIF-MP).....	89
3.3 VSC programmable functions list.....	23	Appendix 1: List of internal parameters for VSC motor	91	
3.4 Parameter function description	34	Appendix 2: VSC parameter setting list	92	
3.4.1 Parameter Group 0: Drive Operation Mode	34			
3.4.2 Parameter Group 2 - Manual/Automatic Restart Modes	37			
3.4.3 Parameter Group 3 - Operating Parameters	38			
3.4.4 Parameter Group 4 - Digital Display Operation Mode	42			
3.4.5 Parameter Group 5 -Multifunction Input Terminals (MFIT)	43			
3.4.6 Parameter Group 6 - Jog and Preset (MFIT) Speed Setting on Keypad.....	47			
3.4.7 Parameter Group 7 - Analogue input signal operation mode	48			
3.4.8 Parameter Group 8 - Multifunction output terminal and output signal operation mode.....	49			
3.4.9 Parameter Group 9 – Drive and Load Protection Modes	52			
3.4.10 Parameter Group 10 – Volts /Hz Pattern Operation Mode	53			
3.4.11 Parameter group 11 - PID operation mode.....	56			
3.4.12 Parameter Group 12 - PID "Limits" and "Out of Range" Mode	57			
3.4.13 Parameter Group 13 - Communication mode.....	59			
3.4.14 Parameter Group 14 - Autotuning.....	59			
3.4.15 Parameter Group 15 - Operation Status and Function Reset.....	59			
3.5 Specification description for built-in PLC function	62			
3.5.1 Basic instructions.....	62			
3.5.2 Function of basic instructions	63			
3.5.3 Application instructions	64			
4. Troubleshooting and Maintenance	73			

Preface

To extend the performance of the product and ensure your safety, please read this manual thoroughly before using the VSD. Should there be any problem when using the product that cannot be solved with the information provided in the manual, contact your nearest Emotron distributor or sales representative who will be willing to help you.

Precautions

The VSD is an electronic product. For your safety, there are symbols such as “Danger” and “Caution” in this manual to remind you to pay attention to safety instructions on handling, installing, operating and checking the VSD. Be sure to follow the instructions for optimum safety.



WARNING: Indicates a potential hazard could cause death or serious personal injury if misused.



CAUTION: Indicates that the VSD or the mechanical system might be damaged if misused.



WARNING: Do not touch any circuit boards or components if the charging indicator is still lit after turned the power off.

Do not wire when the VSD is electrified. Do not check parts and signals on circuit boards during the VSD operation.

Do not disassemble the VSD or modify internal wires, circuits and parts.

Earth the ground terminal of the VSD properly. As per 400 V class, earth to 10 Ohm or below.



CAUTION: Do not perform a voltage test on parts inside the VSD. High voltage will easily destroy these semiconductor parts.

Do not connect the VSD's T1 (U), T2 (V) and T3 (W) terminals to an AC power supply.

CMOS ICs on the VSD's main board are susceptible to static electricity. Do not touch the main circuit board

Products Inspection

Emotron's VSDs are all function tested before delivery. Please check the following when you receive and unpack the VSD:

- The model and capacity of the VSD are the same as those specified in your purchase order.
- That there is not any damage caused by transportation.

Please do not switch on the power, and do contact Emotron's sales representatives if you experience any problems.

Safety Precautions

Operation Precaution

Before Power ON



CAUTION: The line voltage applied must comply with the VSD's specified input voltage.



WARNING: Make sure the main circuit connections are correct. L1, L2 and L3 are power-input terminals and must not be mistaken for T1, T2 and T3. If they are, the VSD might get damaged.



CAUTION: To avoid the front cover disengaging, do not pull the cover during handling or the heat sink may fall off. This will damage the VSD or cause a personal injury, which should be avoided.

To avoid the risk of fire, do not install the VSD on a flammable object. Install it on a non-flammable object such as metal.

If several VSDs are placed in the same control panel, add an extra heat sink to keep the temperature below 40°C to avoid overheating or fire.

When removing or installing the operator, turn OFF the power first, and follow the instructions in the diagram to avoid operator error or no display due to bad contact.



WARNING: According to IEC 61800-3, this product belongs to the restricted sales distribution class. In a domestic environment this product may cause radio interference in which case the user may be required to take appropriate measures.

During Power ON



WARNING: Do not plug or unplug the connectors on the VSD when electrified, otherwise the control panel may be damaged as a result of an erratic transition voltage surge from contact bounce.



When momentary power loss is longer than 2 seconds (the greater the horsepower, the longer the time), the VSD does not have enough power stored to control the circuit. Therefore, when power is regenerated, the operation of the VSD is based on the setup for 1-00 / 2-05 and the condition of the external switch. This is the definition or restart in the following paragraphs.

When the momentary power loss is short, the VSD still has enough power stored to control the circuit. Therefore, when power is regenerated, the VSD will automatically restart according on the setup of 2-00/2-01.

When the VSD is restarted, the operation is based on the setup for 1-00 and 2-05 and the condition of the external switch ( key). Note: The start operation is irrelevant with 2-00/2-01/2-02/2-03.

1. When 1-00=0000, the VSD will not automatically run after restart.

2. When 1-00=0001 and the external switch ( key) is OFF, the VSD will not run after restart.

3. When 1-00=0001, the external switch ( key) is ON, and 2-05=0000, the VSD will run automatically after restart. Note: For safety reasons, please turn off the external switch ( key) after power loss to body if the power resumes suddenly.

To ensure personal and machinery safety, please refer to the description and suggestion in 2-05

Before Operation



WARNING: Make sure the model and capacity are the same as those set with 15-0.



CAUTION: The VSD will flash the power voltage set by 0-07 for 5 seconds when power is applied.

During Operation



WARNING: Do not engage or disengage the motor during operation. Otherwise, the over-current will cause the VSD to disconnect or the main circuit to burn.



WARNING: To avoid electric shock, do not take the front cover off when the power is on.

The motor will restart automatically after stop when the auto-restart function is enabled. In this case, do not get close to the machine.

Note: The stop switch is not used in the same way as the emergency stop switch. It must first be set to be effective.



CAUTION: Do not touch heat-generating components such as the heat sink and braking resistor.

The VSD can drive the motor from low speed to high speed. Verify the motor's range of permitted capacities and the mechanism.

Note the settings related to the braking reactor.

Do not check signals on circuit boards while the VSD is running.



CAUTION: The components cannot be disassembled or checked until five minutes after the power supply has been turned OFF and the indicator is off.

During Maintenance



CAUTION: The VSD should be used in a non-condensed environment with temperature from -10 to +40°C and relative humidity of 95%.



CAUTION: When the VSD top cover has been removed, it can be used in a non-condensed environment with temperature from -10 to +50°C and relative humidity of 95%, but the environment should be free from water and metal dust.

1. Mode Definition

VSD model

Model: VSC48-013

Input voltage

I/P : AC 3 PH

480V 50/60Hz

Output specifications

013 : AC 3PH 0~480V

5.5kW 13 A

EMOTRON AB

VSC 48 001

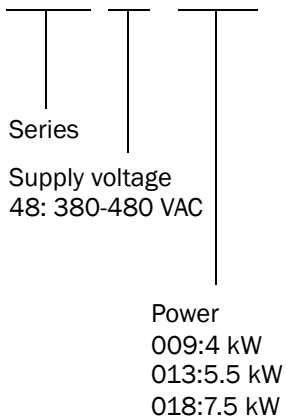

2. Ambient Environment and Installation

2.1 Environment

The environment will directly affect the proper operation and the life span of the inverter, so install the inverter in an environment complying with the following conditions:

Ambient temperature: -10°C - $+40^{\circ}\text{C}$; without cover: -10°C - $+50^{\circ}\text{C}$	
Avoid exposure to rain or moisture.	Avoid direct sunlight.
Avoid oil mist and salinity.	Avoid erosive liquid and gas.
Avoid dust, bats, and small metal pieces.	Keep away from radioactive and flammable materials.
Avoid electromagnetic interference (soldering machine, power machine).	
Avoid vibration (punching machine). Add a vibration-proof pad if the situation cannot be avoided.	
If several inverters are placed in the same control panel, add extra heat sinks to keep the temperature below 40°C .	

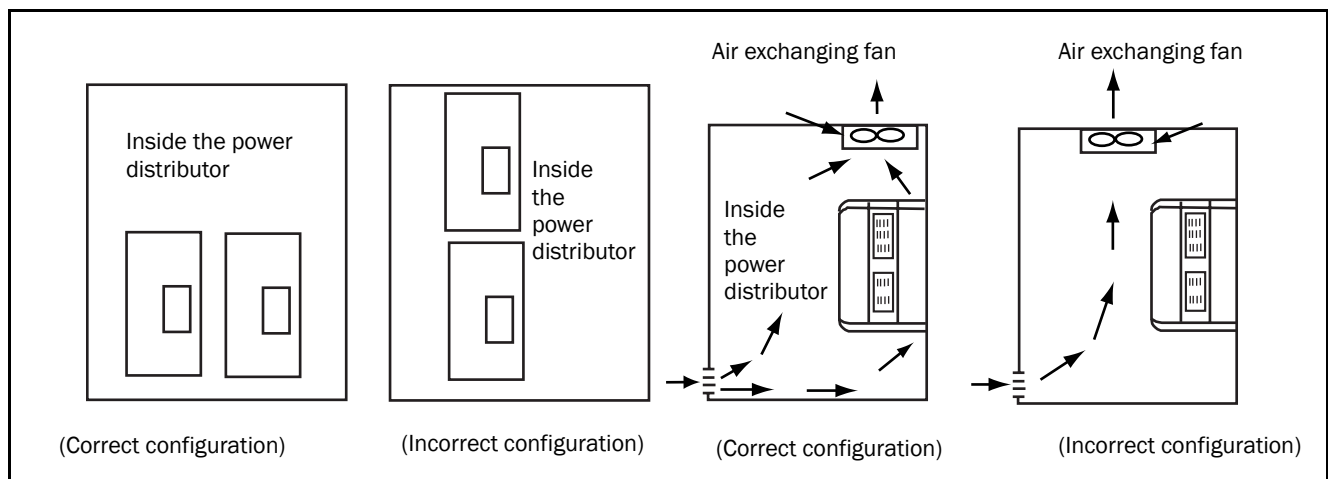

- Place the front side of the inverter onward and top upward to in favour of heat sink.
- Install the inverter according to the following figures: (take the dust proof cover off in favour of heat sinking if it is installed in a box or the environment allows to do so).

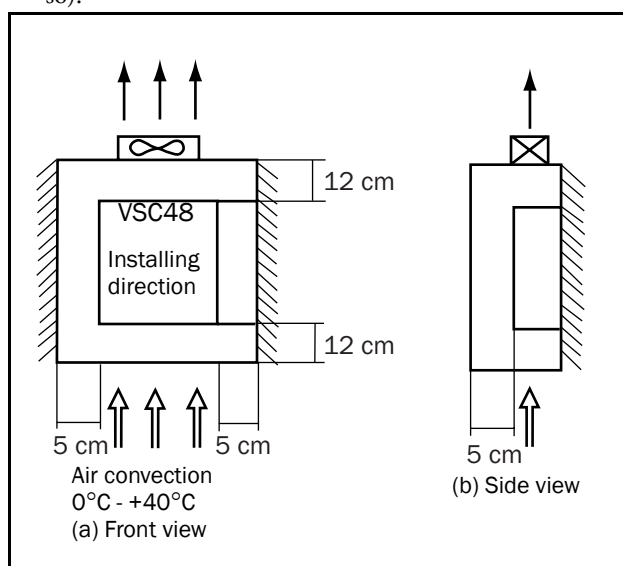

2.2 Environmental precautions

Do not use the inverter in an environment with the following conditions.

<p>Direct sunlight</p>	<p>Corrosive gas and liquid</p>	<p>Oil Mist</p>
<p>Salt</p>	<p>Wind, rain, and water drops may get into</p>	<p>Iron filings, dust</p>
<p>Strong vibration</p>	<p>Extreme low temperature</p>	<p>Excessive high temperature</p>
<p>Electromagnetic wave and ultra high wave (Near an electric welding machine)</p>	<p>Radioactive materials</p>	<p>Inflammable materials</p>

2.3 Inflammable materials

2.3.1 Wiring notes

A. Screwdriver torque:

Wiring with a screwdriver or other tools and follow the torque listed below:

Securing torque			
Power	Power source	Nominal torque for TM1 terminal	
4/5.5/7.5	380-480V	1.5/0.21 (LBS-FT / KG-M)	18.00/20.28 (LBS-IN/KG-CM)

B. Power wires:

Power wires are connecting to L1, L2, L3, T1, T2, T3, P, BR and P1. Choose wires in accordance with the following criteria:

1. Use copper wires only. Deciding diameters of wires should be based on rating working at 105°C.
2. For rating voltage of wires, the minimum voltage of 460VAC type is 600V.
3. For safety reason, the power wires should be fixed by type terminal.

C. Control wires:

Control wires are wires connecting to TM2 control terminal. Choose the wire in accordance with the following criteria:

1. Use copper wires only. Deciding diameters of wires should be based on rating working at 105°C.
2. For rating voltage of wires, the minimum voltage of 460VAC type is 600V.
3. To avoid noise interference, do not route the control wires in the same conduit with power wires and motor wires.

D. Nominal electrical specifications of the terminals Block:

The following list is nominal values of TM1:

Power	Power source	Volts	Amps
4/5.5/7.5	380-480V	600	40A

Note: Nominal values of input and output signals (TM2) – follow the specifications of class 2 wiring.

E. Fuse types

Drive input fuses are provided to disconnect the drive from power in the event that a component fails in the drive's power circuitry. The drive's electronic protection circuitry is designed to clear drive output short circuits and ground

faults without blowing the drive input fuses. The table below shows the VSC input fuse ratings.

To protect the inverter most effectively, use fuses with current-limiting function.

RK5, C/T TYPE FUSE FOR VSC

440V class (3φ)

VSC48-	HP	KW	KVA	100% CONT Output AMPS (A)	Max.kk5 FUSE Rating (A)	Max.CC or T FUSE Rating (A)
009	5	4	6.7	8.8	20	30
013	7.5	5.5	9.9	13	25	35
018	10	7.5	13.3	17.5	30	50

*Fuse ratings are based upon 600V fuses for 460V inverters

Notice

- To avoid shock hazards, do not touch any electrical component when the power is applied or until the power plug has been disconnected for five minutes. Other action should be performed after the charge indicator goes off.
- Do not wire the inverter while it is still electrified. Disregarding this could cause serious injury or death.

This product is designed for use in Pollution Degree 2 environments or equivalent.

2.3.2 Applicable specification of magnetic contactor and wires

Moulded-case circuit breaker/magnetic contactor

- Emotron bears no responsibility to service for failures caused by the following conditions:

A moulded-case circuit breaker is not installed, or an improper or overrated breaker is used, between the power source and the inverter.

A magnetic contactor, a phase capacitor, or a burst absorber is connected between the inverter and the motor.

VSC model	VSC48-		
	009	013	018
Moulded-case circuit breaker made by Emotron	TO-50E 15A	TO-50E 20A	TO-50E 30A

Magnetic contactor (MC) made by Emotron	CN-11	CN-16	CN-18
Main circuit terminals (TM1)	Wire gauge 2.0mm ²	Wire gauge 3.5mm ²	
Signal terminals (TM2)	Wire gauge 0.75mm ² (# 18 AWG), terminal screw M3		

Use three-phase cage induction motor with capacity suitable for the inverter.

- One inverter is driving several motors, the total current of all motors running simultaneously must be less than the rated current of the inverter, and each motor has to be equipped with a proper thermal relay.
- Do not add capacitive component, such as a phase capacitor, LC or RC, between the inverter and the motor.

A: Main circuit's wiring must separate from other high voltage or high current power line to avoid noise interference.:

A noise filter in the output of the main circuit can suppress conductive noise. To prevent radiative noise, the wires

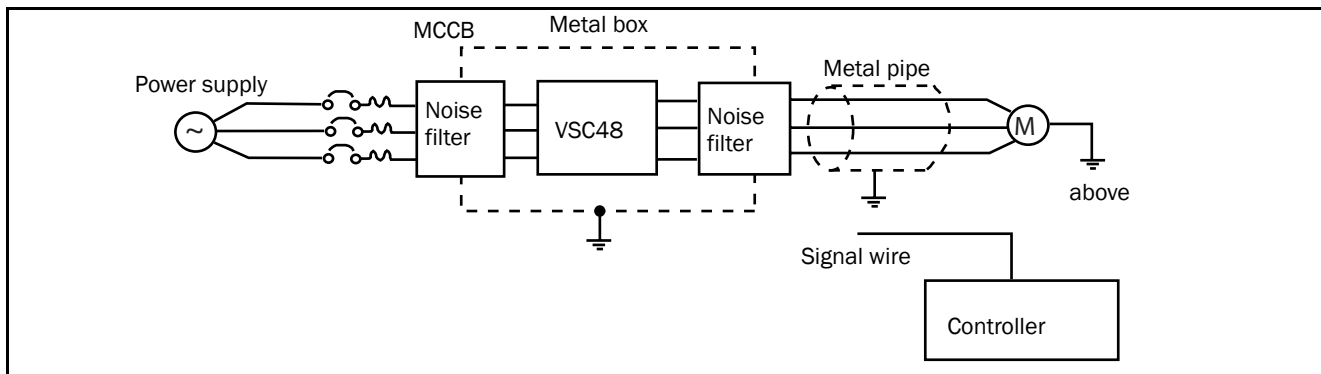

- When the connection between the inverter and the motor is too long, consider the voltage drop of the circuit. Phase-to-phase voltage drop (V) = $3 \times \text{resistance of wire (/km)} \times \text{length of line (m)} \times \text{cur-}$

$\text{rent} \times 10^{-3}$. And the number of carriers must be adjusted based on the length of the line.

The length of the line between the inverter and the motor	Below 25m	Below 50m	Below 100m	Over 100m
Number of carriers allowed	Below 16KHz	Below 12KHz	Below 8KHz	Below 5KHz
Settings of 3-22parameter	16	12	8	5

(B) The wiring of the control circuit must be separated and routed away from the main circuit control line or other high voltage or current power lines to avoid noise interference

- To avoid error actions caused by noise interference, shield the control circuit wiring with a twisted wire, and connect the shielded wire to a ground terminal. Refer to the figure below.

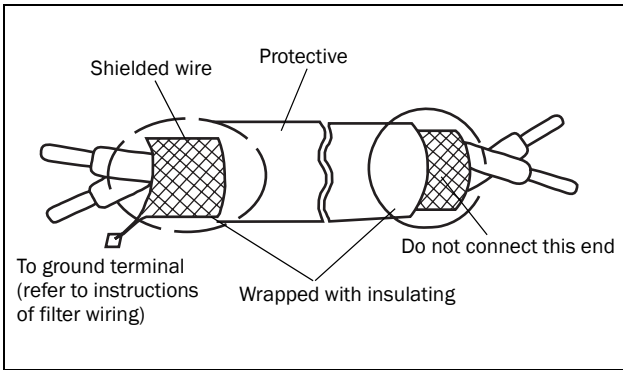

The wiring distance should not exceed 50 m.

(C) Ground the ground terminal of the inverter properly.
For 400V class ground 10Ω or less.

- Ground wiring is based on the electrical equipment technical basis (AWG). The shorter, the better.
- Do not share the ground of the inverter to other high current loads (welding machine, high power motor). Connect the terminals to ground respectively.
- Do not make a loop when several inverters share a common ground point.

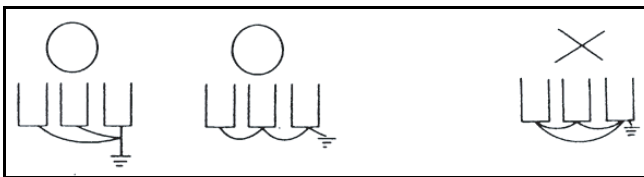

(a) Good (b) Good (c) Bad

(D) To ensure maximum safety, use proper wire gauges (AWG) for the main power circuit and control circuit according to relative regulations.

(E) After wiring, check that the wiring is correct, wires are intact, and terminal screws are secured.

2.4 Specifications

2.4.1 Products Individual Specifications

Three phases, 380 – 480V model

VSC48	009	013	018
Horsepower (HP)	5	7.5	10
Suitable Motor Capacity (KW)	3.7	5.5	7.5
Rated Output Current (A)	8.8	13.0	17.5

Rated Capacity (KVA)	6.7	9.9	13.3
Max. Input Voltage	Three Voltage:380~480V +10% -15% 50/60Hz ± 5%		
Max. Output Voltage	Three Voltage: 380~480V		
Input Current (A)	11.6	17	23
Net Weight (KG)	2.2	6.6	6.6
Allowable momentary power loss time (second)	2.0	2.0	2.0

2.4.2 General Specifications

Item	VSC TYPE	
Control Mode	V/F or Current Vector Control	
Frequency Control	Range	0.1~650.0 Hz
	Start control torque	150%/1Hz (Current Vector)
	Speed control range	1:50 (Current Vector)
	Speed Control Precision	±0.5% (Current Vector)
	Setting resolution	Digital:0.01Hz (Note *1) Analogue: 0.06Hz/ 60Hz (10bits)
	Keypad setting	Set directly with keys or the VR on the keypad
	Display Function	Four digital LED (or 2×16 LCD) and status indicator; display frequency/ speed/ line speed/ DC voltage/ Output voltage/ Current/ Rotation direction/ Inverter parameter/ Trouble Log/ Program Version
	External signal setting	External variable resistor/ 0-10V/ 0-20mA/ 10-0V/ 20-0mA Performs up/down controls, speed control or automatic procedure control with multifunctional contacts on the terminal block (TM2)
Frequency Limit Function	Respectively setting upper/lower frequency limits and three-stage prohibited frequencies	

Carrier frequency	2 ~ 16 kHz
V/F pattern	18fixable patterns, 1programable curve
Acc/Dec control	Two-stage Acc/Dec time (0.1 – 3,600 seconds) and two-stage S curves (refer to descriptions on 3-05)
Multifunctional analog output	6 functions (refer to description on 8-00/8-01)
Multifunctional input	30 functions (refer to description on 5-00~5-06)
Multifunctional output	16 functions (refer to description on 8-02~8-03)
Digital Input Signal	NPN (SINK) / PNP (SOURCE) toggle
Other Function	Momentary Power Loss Restart, Speed Search, Overload Detection, 8 preset speeds (PLC use 16 preset speeds). Acc/Dec Switch (2 Stages), S Curves, 3-wire Control, PID control, torque boost, Slip Compensation, Frequency Upper/ Lower Limit, Auto energy saving, Modbus slave and PC/PDA Link, Auto Restart, Built-in Simple PLC Function.

Item	VSC TYPE
Communication Control	Control by RS232 or RS485 One to one or One to more (RS485 ONLY) control. BAUD RATE/STOP BIT/PARITY/bit can be set
Braking Torque	About 20%, the model built-in braking transistor and connected braking resistor is 100%
Operation temperature	-10 ~ 50°C (note 2)
Storage temperature	-20 ~ 60°C
Humidity	0 – 95% Relative Humidity (Non-condense)
Vibration Sustention	1G (9.8m/s ²)
EMC	Comply with requirement EN 61800-3 (1st environment, restricted distribution).
LVD	Comply with requirement EN 50178
Enclosure	IP20 (NEMA 1 by external box attached)
Safety Level	UL 508C

Protective Functions	Overload protection	The relays to protect the motor (the curve can be set) and the inverter (150% / 1min)
	FUSE protection	The motor stops after FUSE melt
	Over Voltage	400V class DC Voltage 820V
	Under Voltage	400V class DC Voltage 380V
	Momentary Power Loss Restart	Stop for more than 15ms-power-loss can be restarted with spin start after momentary power loss in Max 2 sec.15ms
	Stall Prevention	Stall prevention for Acceleration/ Deceleration/ Operation.
	Short-circuit output terminal	Electronic Circuit Protection
	Grounding Fault	Electronic Circuit Protection
	Other Function	Protection for overheating of heat sink, over torque detection, error contact control, reverse restriction, restrictions for direct start after power up and error recovery, parameter lock up.

NOTE 1: The setting resolution of above 100Hz is 0.1Hz when controlled with operation keypad, and 0.01 Hz when controlled using computer (PC) or programmable controller (PLC).

NOTE 2: -10 ~ 50°C in distributor (without dust proof cover), -10 ~ 40°C outside distributor (with dustpans cover).

3. Software Index

3.1 Keypad description

3.1.1 Keypad display and operation instructions

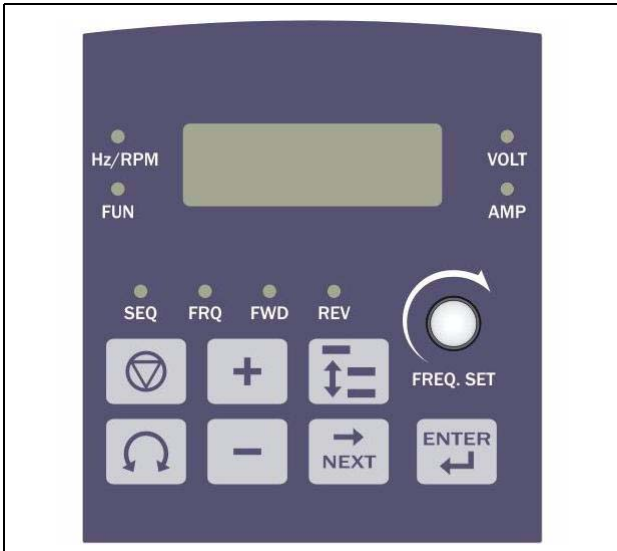



1. SEQ LED: 1_00=1/2/3, LED Lit.
2. FRQ LED: 1_06=1/2/3/4, LED Lit.
3. FWD LED: Forward Direction, LED action (flash if stopped, Stays lit during operation).
4. REV LED: Reverse Direction, LED action (flash if stopped, Stays lit during operation)).
5. 4-action LED: FUN, Hz/RPM, VOLT and AMP and four 7-segment display, refer to operating instructions for the keypad.

CAUTION: To avoid damaging the keypad, do not operate it with a screwdriver or any other sharp and hard tool.

*1: The VSD will flash the current setting of 0-07 (power supply voltage) after power up.



Remote/Local Mode

Local mode – Operation Command with the  key on the keypad

– Frequency Command with the   key on the keypad

Remote mode – Operating Command by 1-00

– Frequency Command by 1-06

To Change the Remote/Local mode, you must push 
and  at the same time.

The Remote /Local mode of change can used in  mode, it cannot be used in Run mode.

3.1.2 Operating instructions for the keypad

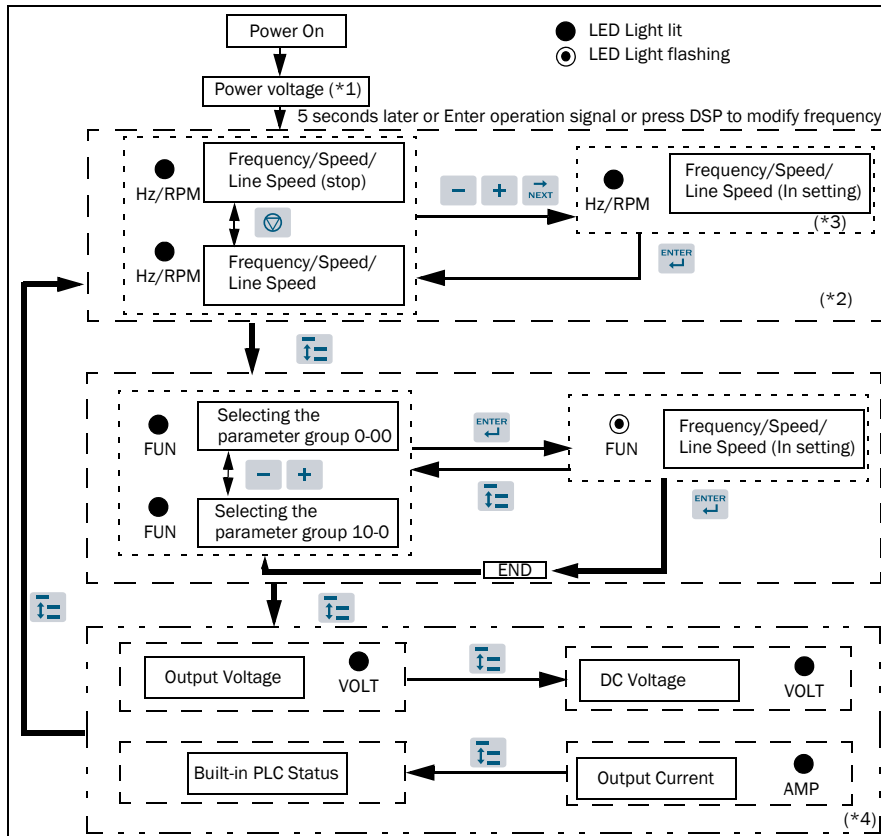

*2: 4-04, 4-05 determines the displaying of frequency, speed or line speed.

*3: It is not necessary to press the ENTER key when stopped for modification. Refer to example 1 and 2.

*4: Whether output current, output voltage, DC voltage, status of built-in PLC is displayed or not is determined by 4-00 to 4-03 respectively.

3.1.3 Operating instructions for the LED keypad

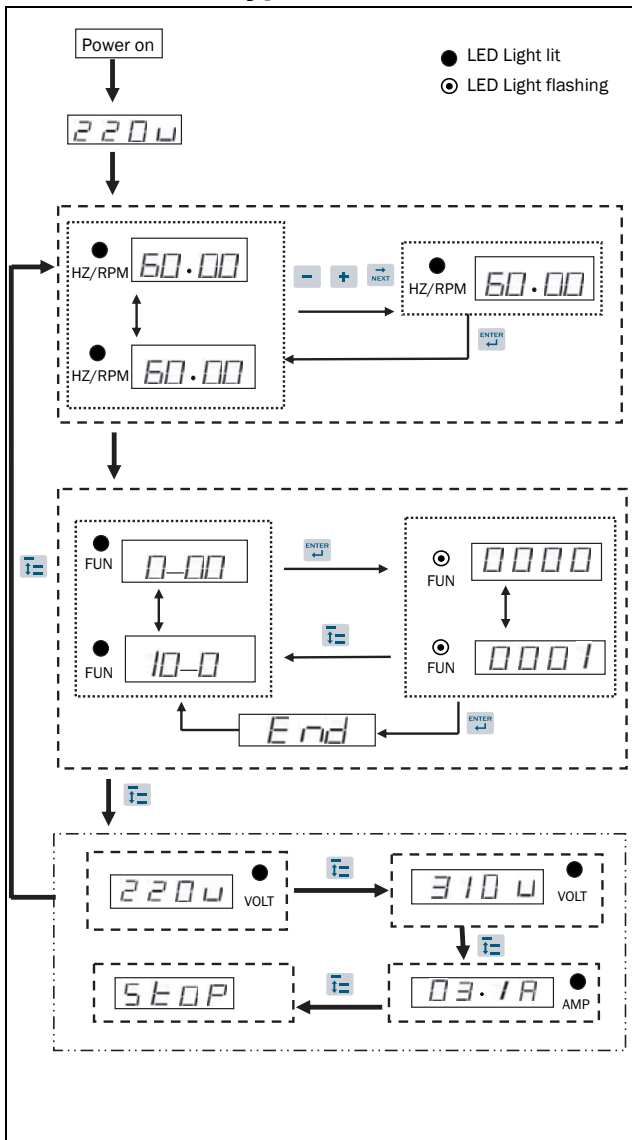

5 seconds later or Enter operation signal or press DSP to modify the display frequency.

3.1.4 Keypad operation

Example 1. Modify frequency for stopping.

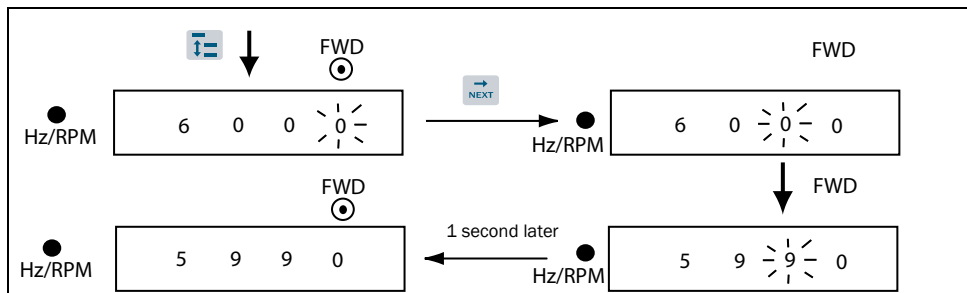

Example 2. Modify frequency for operating

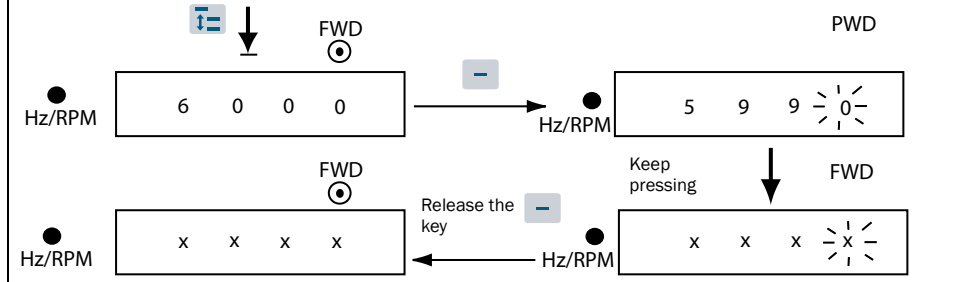

NOTE: XXXX shows the preset output frequency. The value ranges from 59.58 to 0 Hz, depending on the length of time the **-** key is pressed

Example 3. Modify frequency for running

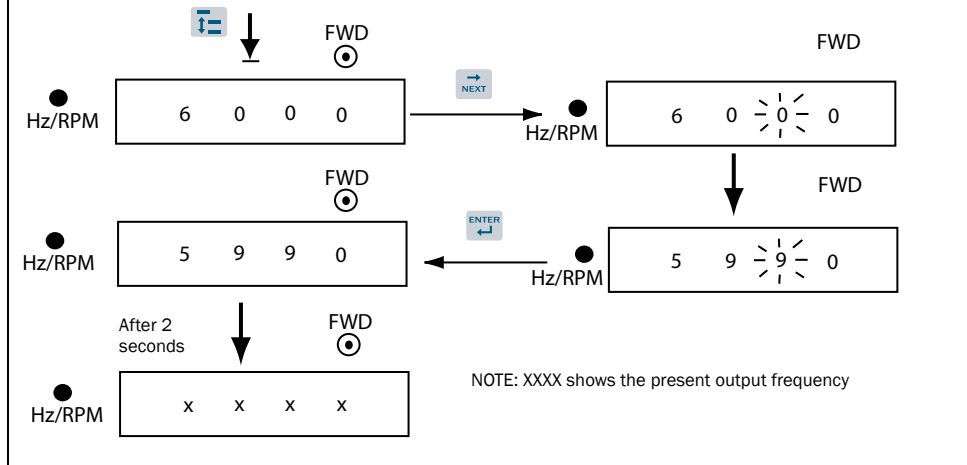

NOTE: XXXX shows the present output frequency

Example 4. Modify the parameter value

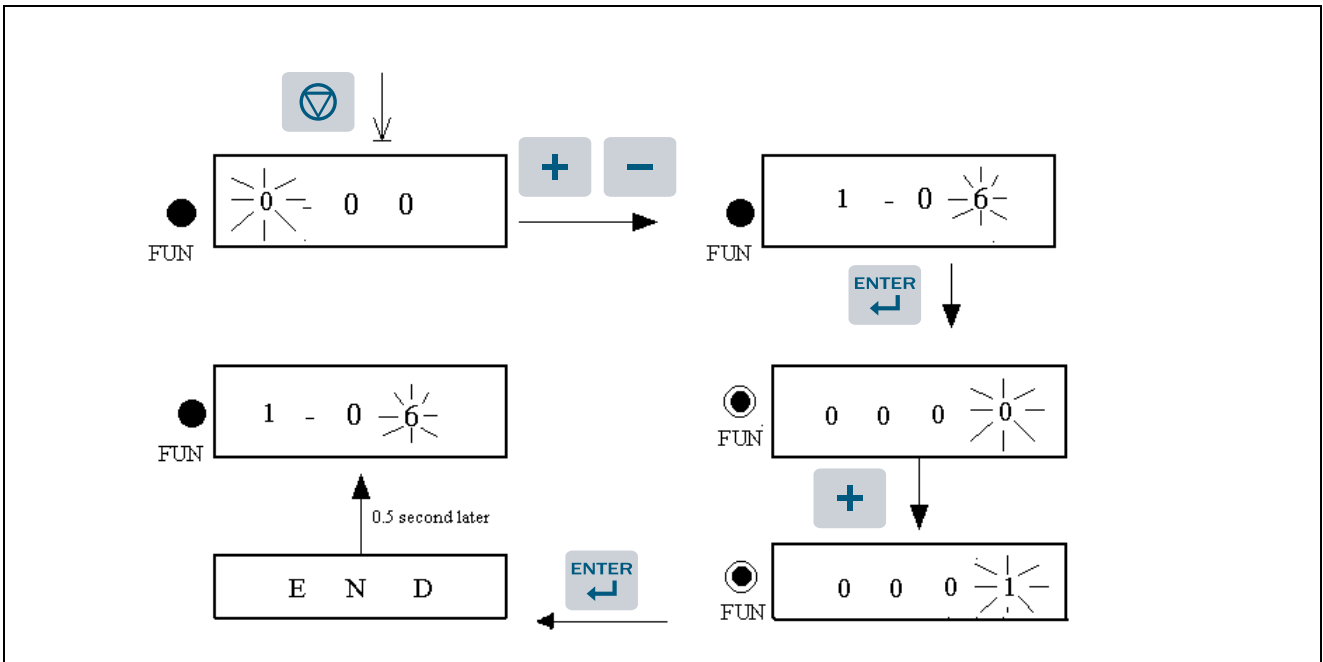

Example 5 Operation control

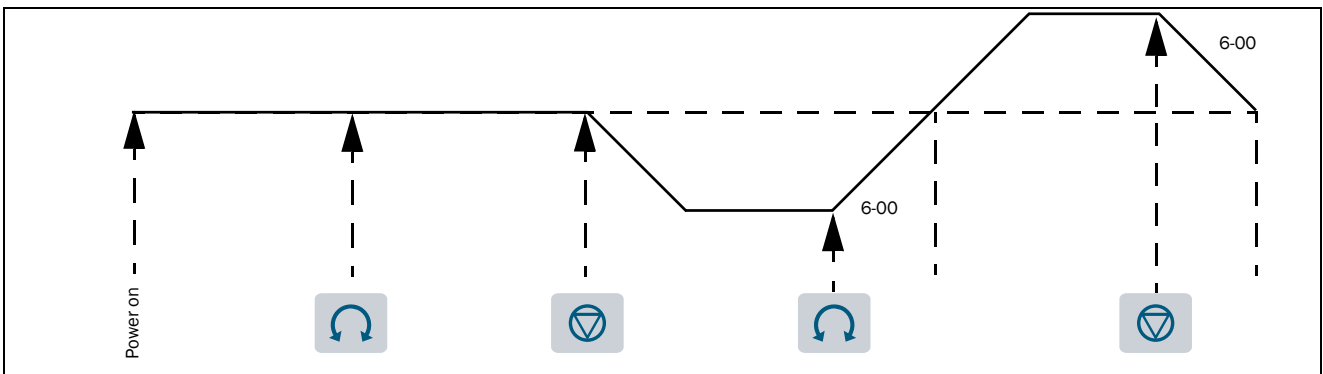

FWD LED	●	○	○	●	●
REV LED	○	●	●	○	○

●: LED lit, ●: LED flash, ○: LED goes out

3.2 Control mode selection

The VSC series VSD has three control modes:

1. General Vector Control Mode
2. VT Vector Control Mode (especially for blower, pump).
3. V/F Control Mode

The user can choose these modes using the digital keypad according to the application characteristics. The factory setting is general vector control mode. Before operation, please set the control mode and the relative parameters of the motor in accordance with the following flow chart. (The Vector control mode is only suitable for an VSD with the same capacity as the motor, or a class larger or smaller)

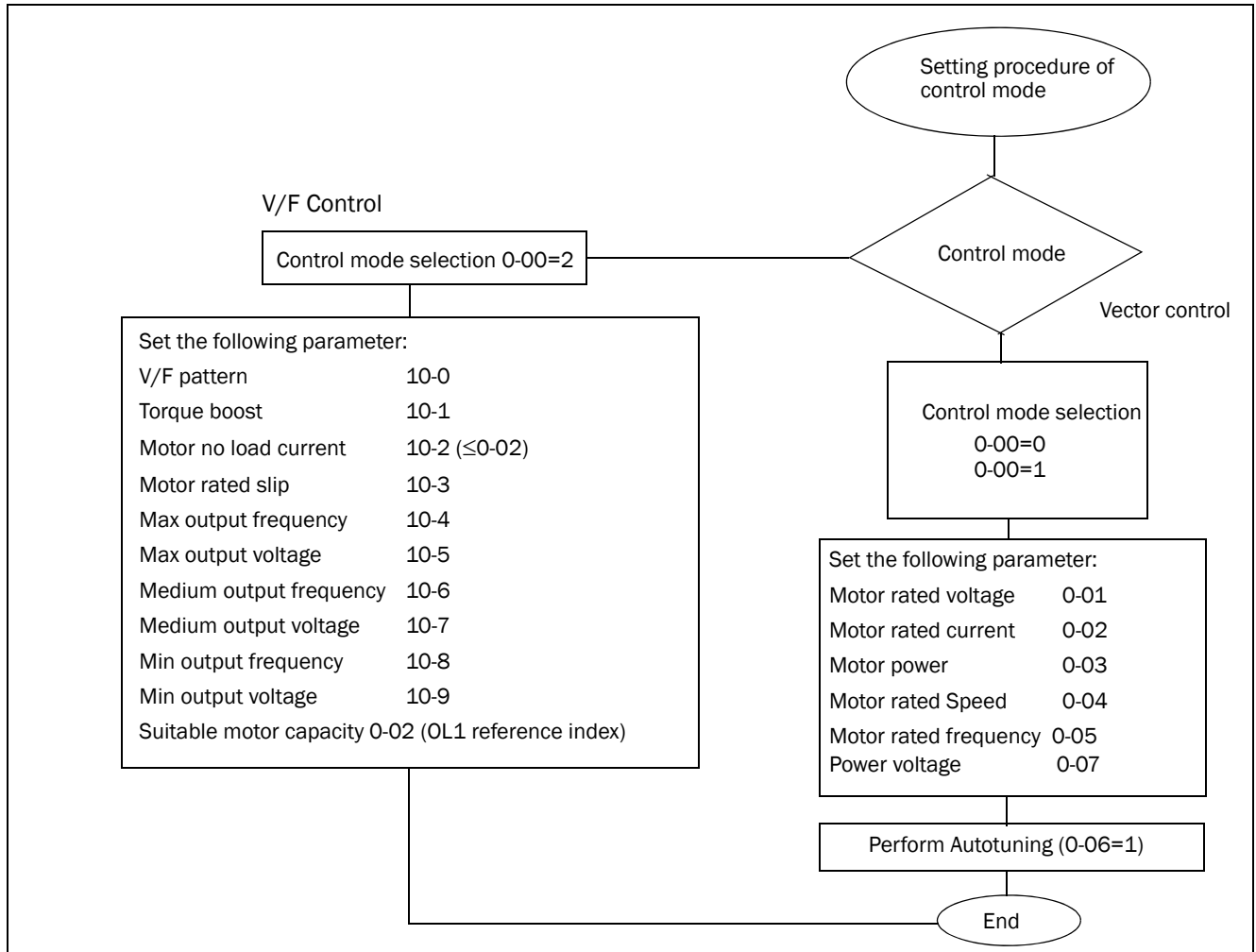

3.3 VSC programmable functions list

NOTE:

1. Use V/F Control Mode if:

- (1) You want one VSD to drive several motors simultaneously.
- (2) The motor's nameplate is unknown or the motor specifications are too specialised, this will cause an autotuning fault.
- (3) The specification of VSD and motor differ by more than 1 class.

2. One VSD drives several motors (only V/F mode available), set the motor parameter to comply with the following rules:

- (1). As for the current, total up the rated current of all motors.
- (2). As for others, input correct VF pattern parameter (10-4 to 10-9).

3. When the nameplate of the motor is unknown, the VSD will set the internal parameter as if for the standard Emotron motor.

4. When parameter 0-00 is set to 2, the keypad will display 'Err2' when performing autotuning.

5. When using Vector control, set to 0-01 to 0-05 for max. and min. values with a standard motor specification limit (one level less and one level more). When using V/F Control, no range to be set.

Parameter Group No.	Description
0-	Drive Operation Mode
1-	Start/Stop and Frequency Control Modes
2-	Manual/Automatic Restart Modes
3-	Operating Parameters
4-	Digital Display Operation Mode
5-	Multifunction Input Terminals (MFIT)
6-	Jog, and Preset (MFIT) Speed Setting on Keypad
7-	Analogue Input Signal Operation
8-	Multifunction Output Relays and Output Signal Operation
9-	Drive and Load Protection Modes
10-	Volts/Hz Pattern Operation Mode
11-	PID Operation Mode
12-	PID "Limits" and "Out of Range" Mode
13-	Communication Mode
14-	Motor Autotuning Parameters
15-	Drive Status and Function Reset

0- Drive Operation Mode

Function Code No.	Description	Range/Code	Factory Setting	Remarks
0-00	Control Mode	0000:Vector (General Purpose) 0001:Vector (Variable Torque) 0002:Volts/Hz (Refer to Parameter Group 10-Volts/Hz Mode)	0000	*3
0-01	Motor Rated Voltage (VAC)	----		*3*5
0-02	Motor Rated Current (Amp)	----		*3*5
0-03	Motor Rated Power (kW)	----		*3*5
0-04	Motor Rated Speed (RPM) X100*7	----		*3*5
0-05	Motor Rated Frequency (Hz)	----		*3*5
0-06	Motor Parameter Autotuning	0000: Invalid 0001: Valid	0000	
0-07	AC Line Input Voltage (VAC)	440V SERIES:323.0 to 528.0		*3

1- Start/Stop and Frequency Control Modes

Function Code No.	Description	Range/Code	Factory Setting	Remarks
1-00	Run Command Source Selection	0000: Keypad 0001: External Run/Stop Control (See 1-01) 0002: Communication 0003: Built-In PLC	0000	
1-01	Run/Stop-Forward/Reverse Operation Mode with External Terminals	0000: Forward/Stop-Reverse/Stop 0001: Run/Stop-Forward/Reverse 0002: 3-Wire Control Mode- Run/Stop	0000	
1-02	Prohibition of Reverse operation	0000: Enable Reverse Command 0001: Disable Reverse Command	0000	
1-03	Keypad Stop Button	0000: Stop Button Enabled 0001: Stop Button Disabled	0000	
1-04	Starting Method Selection	0000: Normal Start 0001: Enable Speed Search	0000	
1-05	Stopping Method Selection	0000: Controlled Deceleration-to- Stop with DC Injection Braking (Rapid Stop) 0001: Free run Stop		
1-06	Frequency Command Source Selection	0000: Keypad 0001: Potentiometer on Keypad 0002: External analogue signal Input or Remote Potentiometer 0003: Up/Down Frequency Control using MFIT (S1 - S6) 0004: Communication setting frequency 0005: Impulse (S5) setting frequency (ver2.3)	0000	
1-07	Keypad Operation with Up/Down Keys in Run Mode	0000: "Enter" must be pressed after frequency change with the up/down keys on keypad. 0001: Frequency will be changed directly when the up/down keys are pressed	0000	

2- Manual/Automatic Restart Modes

Function Code No.	Description	Range/Code	Factory Setting	Remarks
2-00	Momentary Power Loss and Restart	0000: Momentary power loss and restart disable 0001: Momentary power loss and restart enable 0002: Momentary power loss and restart enable while CPU is operating. (According to the capacity of DC power)	0000	
2-01	Momentary Power Loss Ride-Thru Time (s)	0.0 to 2.0	0.5	
2-02	Auto Restart Delay Time (s)	0.0 to 800.0	0.0	
2-03	Number of Auto Restart Attempts	0 to 10	0	
2-04	Auto Restart Method	0000: Enable Speed Search 0001: Normal Start	0000	
2-05	Direct Running After Power Up	0000: Enable Direct running after power up 0001: Disable Direct running after power up	0001*8	
2-06	Delay-ON Timer (s)	0.0 to 300.0	0.0	
2-07	Reset Mode Setting	0000: Enable Reset Only when Run Command is Off 0001: Enable Reset when Run Command is On or Off	0000	
2-08	Kinetic Energy Back-up Deceleration Time	0.0: Disable 0.1 to 25.0: KEB Deceleration Time	0.0	

3- Operating Parameters

Function Code No.	Description	Range/Code	Factory Setting	Remarks
3-00	Frequency Upper Limit (Hz)	0.01 to 650.00	50.00 60.00	*4
3-01	Frequency Lower Limit (Hz)	0.00 to 650.00	0.00	
3-02	Acceleration Time #1 (s)	0.1 to 3600.0	10.0	*1
3-03	Deceleration Time #1 (s)	0.1 to 3600.0	10.0	*1
3-04	S-Curve Acc/Dec #1 (s)	0.0 to 4.0	0.2	
3-05	S-Curve Acc/Dec #2 (s)	0.0 to 4.0	0.2	
3-06	Acceleration Time #2 (MFIT) (s)	0.1 to 3600.0	10.0	*1
3-07	Deceleration Time #2 (MFIT) (s)	0.1 to 3600.0	10.0	*1
3-08	Jog Acceleration Time (MFIT) (s)	0.1 to 25.5	0.5	*1
3-09	Jog Deceleration Time (MFIT) (s)	0.1 to 25.5	0.5	*1
3-10	DC Injection Brake Start Frequency (Hz)	0.1 to 10.0	1.5	
3-11	DC Injection Brake Level (%)	0.0 to 20.0	5.0	*7
3-12	DC Injection Brake Time (s)	0.0 to 25.5	0.5	
3-13	Skip Frequency #1 (Hz)	0.00 to 650.00	0.0	*1
3-14	Skip Frequency #2 (Hz)	0.00 to 650.00	0.0	*1
3-15	Skip Frequency #3 (Hz)	0.00 to 650.00	0.0	*1
3-16	Skip Frequency Bandwidth (±Hz)	0.00 to 30.00	0.0	*1
3-17	Parameter Lock	0000: Enable all Functions 0001: 6-00 - 6-08 cannot be changed 0002: All Functions Except 6-00 - 6-08 cannot be changed 0003: Disable All Function	0000	
3-18	Copy Unit	0000: Disable 0001: VSD to Copy Unit 0002: Copy Unit to VSD 0003: Verify	0000	
3-19	Fan Control	0000: Auto (Depend on temp.) 0001: Operate while in RUN mode 0002: Always Run 0003: Always Stop	0000	
3-20	Energy Saving Mode *1	0000: Disabled 0001: Controlled by MFIT at Set Frequency	0000	*6
3-21	Energy Saving Gain (%) *1	0 to 100	80	*6
3-22	Carrier Frequency (kHz)	2 to 16	10	
3-23	Centre Frequency (CF) of Traverse Run (%)	5.00 to 100.00	20.00	
3-24	Amplitude (A) of Traverse Run (%)	0.1 to 20.0	10.0	
3-25	Drop (D) of Traverse Run (%)	0.0 to 50.0	0.0	
3-26	Acc Time (AT) of Traverse Run (s)	0.5 to 60.0	10.0	
3-27	Dec Time (DT) of Traverse Run (s)	0.5 to 60.0	10.0	
3-28	Rise (X) Deviated Traverse (%)	0.0 to 20.0	10.0	
3-29	Lower (Y) Deviated Traverse (%)	0.0 to 20.0	10.0	

NOTE: 1. Energy Saving Mode is available only in Volts/Hz Mode (0-00=0002).

4- Digital Display Operation Mode

Function Code No.	Description	Range/Code	Factory Setting	Remarks
4-00	Motor Current Display Selection	0000: Disable Motor Current Display 0001: Enable Motor Current Display	0000	*1
4-01	Motor Voltage Display Selection	0000: Disable Motor Voltage Display 0001: Enable Motor Voltage Display	0000	*1
4-02	DC Bus Voltage Display Selection	0000: Disable Bus Voltage Display 0001: Enable Bus Voltage Display	0000	*1
4-03	PLC Status Display Selection	0000: Disable PLC Status Display 0001: Enable PLC Status Display	0000	*1
4-04	Custom Units (Line Speed) Value	0 to 9999	1800	*1
4-05	Custom Units (Line Speed) Display Mode	0000: Drive Output Frequency is displayed 0001: Line Speed is displayed in Integer (xxxx) 0002: Line Speed is displayed with one decimal place (xxx.x) 0003: Line Speed is displayed with two decimal places (xx.xx) 0004: Line Speed is displayed with three decimal places (x.xxx)	0000	*1
4-06	PID Feedback Display Selection	0000: Disable PID Feedback Display 0001: Enable PID Feedback Display	0000	*1

5- Multifunction Input Terminals (MFIT)

Function Code No.	Description	Range/Code	Factory Setting	Remarks
5-00	Multifunction Input Term. S1	0000: Forward/Stop Command *1 0001: Reverse/Stop Command *2 0002: Preset Speed #1 (6-02) 0003: Preset Speed #2 (6-03)	0000	
5-01	Multifunction Input Term. S2	0004: Preset Speed #3 (6-05) *3 0005: Jog 0006: Acc/Dec #2	0001	
5-02	Multifunction Input Term. S3	0007: Emergency Stop A Contact 0008: Base Block 0009: Speed Search 0010: Energy Saving	0002	
5-03	Multifunction Input Term. S4	0011: Control Signal Selection 0012: Communication Selection 0013: Acc/Dec Disabled 0014: Up Command	0003	
5-04	Multifunction Input Term. S5	0015: Down Command 0016: Master/Auxiliary Speed 0017: PID Function Disabled 0018: Reset	0004	
5-05	Multifunction Input Term. S6	0019: Encoder input terminal (terminal S5) 0020: PID feedback signal A12 (terminal) 0021: AI2 Bias signal 1 input 0022: AI2 Bias signal 2 input (terminal S6)	0018	
5-06	Multifunction Input Term. AIN	0023: Analogue input (terminal AIN) 0024: PLC Application 0025: Traverse Run 0026: Traverse Run upper deviation 0027: Traverse Run lower deviation 0028: Power Source Detect for KEB Function 0029: Emergency Stop B Contact *7	0023	

5-07	Multifunction Input Term. S1 - S6 Signal Verification Scan Time (ms X 4)	1 to 100	5	
5-08	Stop Mode Using MFIT	0000: When the MFITs are Programmed for Up/Down Frequency Control, the Set Frequency will remain when the Drive stops. And when the Drive stops, Up/Down Function is disabled. 0001: Up/Down is used. The preset frequency is reset to 0 Hz as the VSD stops. 0002: When the MFITs are Programmed for Up/Down Frequency Control, the Set Frequency will remain when the Drive stops. And when the Drive stops, Up/Down Function is enabled. *7	0000	
5-09	Step of Up/Down Function (Hz)	0.00 to 5.00	0.00	
5-10	Encoder Impulse Ratio	0.001 to 9.999	1.000	*7
5-11	Select the source of auxiliary frequency command	0 to 4	0	*7

NOTE:

1. To switch to Run/Stop with Function 1-01=0001.

2. To switch to Forward/Reverse with Function 1-01=0001.

3. Preset Speed #3 is obtained by activating Terms. S3 and S4 simultaneously.

6- Jog, and Preset (MFIT) Frequency Setting on Keypad

Function Code No.	Description	Range/Code	Factory Setting	Remarks
6-00	Keypad Frequency (Hz)	0.00 to 650.00	5.00	*1
6-01	Jog Frequency (Hz)	0.00 to 650.00	2.00	*1
6-02	Preset Speed #1 (Hz)	0.00 to 650.00	5.00	*1
6-03	Preset Speed #2 (Hz)	0.00 to 650.00	10.00	*1
6-04	Preset Speed #3 (Hz)	0.00 to 650.00	20.00	*1
6-05	Preset Speed #4 (Hz)	0.00 to 650.00	30.00	*1
6-06	Preset Speed #5 (Hz)	0.00 to 650.00	40.00	*1
6-07	Preset Speed #6 (Hz)	0.00 to 650.00	50.00	*1
6-08	Preset Speed #7 (Hz)	0.00 to 650.00	60.00	*1

7- Analogue Input Signal Operation

Function Code No.	Description	Range/Code	Factory Setting	Remarks
7-00	AIN Gain (%)	0 to 200	100	*1
7-01	AIN Bias (%)	0 to 100	0	*1
7-02	AIN Bias Selection	0000: Positive 0001: Negative	0000	*1
7-03	AIN Slope	0000: Positive 0001: Negative	0000	*1
7-04	AIN Signal Verification Scan Time (AIN, AI2) (ms x 2)	1 to 100	50	
7-05	AI2 Gain (%) (S6)	0 to 200	100	*1

**NOTE: Group 7 is available when 5-06=0023
(AIN term.=Analogue input)**

8- Multifunction Output Relays and Output Signal Operation

Function Code No.	Description	Range/Code	Factory Setting	Remarks
8-00	Analogue Output Voltage Mode (0 - 10 VDC, Term. FM+)	0000: Output Frequency 0001: Frequency Setting 0002: Output Voltage 0003: DC Voltage 0004: Output Current 0005: PID Feedback *7	0000	*1
8-01	Analogue Output Gain (%)	0 - 200	100	*1
8-02	Output Relay R1 Operation Mode	0000: Run 0001: Frequency Reached (Frequency Command) (Set Frequency \pm 8-05) 0002: Set Frequency (8-04 \pm 8-05) 0003: Frequency Threshold Level (> 8-04) - Frequency Reached 0004: Frequency Threshold Level (< 8-04) - Frequency Reached 0005: Over torque Threshold Level 0006: Fault	0006	
8-03	Output Relay R2 Operation Mode	0007: Auto Restart 0008: Momentary AC Power Loss 0009: Rapid Stop Mode 0010: Coast-to-Stop Mode 0011: Motor Overload Protection 0012: Drive Overload Protection 0013: PID Feedback Signal Loss 0014: PLC Operation 0015: Power On *7	0000	
8-04	Frequency Reached (Hz) (Refer to 8-02: 0001)	0.00 to 650.00	0.00	*1
8-05	Frequency Reached Bandwidth (\pm Hz)	0.00 to 30.00	2.00	*1

9- Drive and Load Protection Modes

Function Code No.	Description	Range/Code	Factory Setting	Remarks
9-00	Trip Prevention Selection During Acceleration	0000: Enable Trip Prevention During Acceleration 0001: Disable Trip Prevention During Acceleration	0000	
9-01	Trip Prevention Level During Acceleration (%)	50 to 300	200 150*9	
9-02	Trip Prevention Selection During Deceleration	0000: Enable Trip Prevention During Deceleration 0001: Disable Trip Prevention During Deceleration	0000	
9-03	Trip Prevention Level During Deceleration (%)	50 to 300	200 150*9	
9-04	Trip Prevention Selection in Run Mode	0000: Enable Trip Prevention in Run Mode 0001: Disable Trip Prevention in Run Mode	0000	
9-05	Trip Prevention Level In Run Mode (%)	50 to 300	200 150*9	
9-06	Trip Prevention Deceleration Time Selection in Run Mode	0000: Trip Prevention Deceleration Time Set by 3-03 0001: Trip Prevention Deceleration Time Set by 9-07	0000	
9-07	Deceleration Time In Trip Prevention Mode (s)	0.1 to 3600.0	3.0	
9-08	Electronic Motor Overload Protection Operation Mode	0000: Enable Electronic Motor Overload Protection 0001: Disable Electronic Motor Overload Protection	0000	
9-09	Motor Type Selection	0000: Electronic Motor Overload Protection Set for Non-VSD Duty Motor 0001: Electronic Motor Overload Protection Set for VSD Duty Motor	0000	
9-10	Motor Overload Protection Curve Selection	0000: Constant Torque (OL=103%) (150% for 1 Minute) 0001: Variable Torque (OL=113%) (123% for 1 Minute)	0000	
9-11	Operation After Overload Protection is Activated	0000: Coast-to-Stop After Overload Protection is Activated 0001: Drive Will Not Trip when Overload Protection is Activated (OL1)	0000	
9-12	Over torque Detection Selection	0000: Disable Over torque Operation 0001: Enable Over torque Operation Only if at Set Frequency 0002: Enable Over torque Operation while the Drive is in Run Mode	0000	
9-13	Operation After Over torque Detection is Activated	0000: Drive will Continue to Operate After Over torque is Activated 0001: Coast-to-Stop After Over torque is Activated	0000	
9-14	Over torque Threshold Level (%)	30 to 200	160	
9-15	Over torque Activation Delay Time (s)	0.0 to 25.0	0.1	

10- Volts/Hz Operation Mode

Function Code No.	Description	Range/Code	Factory Setting	Remarks
10-0	Volts/Hz Patterns	0 to 18	0/9	*4*6
10-1	Volts/Hz Curve Modification (Torque Boost) (%)	0 to 30.0	0.0	*1*6
10-2	Motor No Load Current (Amps AC)	----		*5*6
10-3	Motor Slip Compensation (%)	0.0 to 100.0	0.0	*1*6
10-4	Maximum Frequency (Hz)	0.20 to 650.00	50.00/ 60.00	*4*6
10-5	Maximum Frequency Voltage Ratio (%)	0.0 to 100.0	100.0	*6
10-6	Mid Frequency (Hz)	0.10 to 650.00	25.00/ 30.00*7	*4*6
10-7	Mid Frequency Voltage Ratio (%)	0.0 to 100.0	50.0*7	*6
10-8	Minimum Frequency (Hz)	0.10 to 650.00	0.50/ 0.60	*6
10-9	Minimum Frequency Voltage Ratio (%)	0.0 to 100.0	1.0*7	*6

11- PID Operation Mode

Function Code No.	Description	Range/Code	Factory Setting	Remarks
11-0	Mode Selection	0000: Disabled 0001: Bias D Control 0002: Feedback D Control 0003: Bias D Reversed Characteristics Control 0004: Feedback D Reversed Characteristics Control 0005: Frequency Command + Bias D Control 0006: Frequency Command + Feedback D Control 0007: Frequency Command + Bias D Reversed Characteristics Control 0008: Frequency Command + Feedback D Reversed Characteristics Control	0000	
11-1	Feedback Gain (%)	0.00 to 10.00	1.00	*1
11-2	Proportional Gain (%)	0.0 to 10.0	1.0	*1
11-3	Integration Time (s)	0.0 to 100.0	10.0	*1
11-4	Differentiation Time (s)	0.00 to 10.00	0.00	*1
11-5	PID Offset	0000: Positive 0001: Negative	0000	*1
11-6	PID Offset Adjust (%)	0 to 109	0	*1
11-7	Output Lag Filter Time (s)	0.0 to 2.5	0.0	*1

12- PID "Limits" and "Out of Range" Mode

Function Code No.	Description	Range/Code	Factory Setting	Remarks
12-0	Feedback Loss Detection Mode	0000: Disabled 0001: Enabled - Drive Continues to Operate After Feedback Loss 0002: Enabled - Drive "STOPS" After Feedback Loss	0000	
12-1	Feedback Loss Detection Level (%)	0 to 100	0	
12-2	Feedback Loss Detection Delay Time (s)	0.0 to 25.5	1.0	
12-3	Integration Limit Value (%)	0 to 109	100	*1
12-4	Integration Value Resets to Zero when Feedback Signal Equals the Intended Value	0000: Disabled 0001: 1 Second 0030: 30 Seconds	0000	
12-5	Allowable Integration Error Margin (Units) (1 Unit=1/8192)	0 to 100	0	
12-6	PID Feedback signal	0000: 0-10V or 0-20mA 0001: 2-10V or 4-20mA	0000	*7
12-7	Sleep Function Operation Level	0.00 to 650.00	0.0	
12-8	Sleep Function Delay Time	0.0 to 25.5	0.0	

13- Communication Mode

Function Code No.	Description	Range/Code	Factory Setting	Remarks
13-0	Assigned Communication Station Number	1 to 254	1	*2*3
13-1	Baud Rate Setting (bps)	0000: 4800 0001: 9600 0002: 19200 0003: 38400	0003	*2*3
13-2	Stop Bit Selection	0000: 1 Stop Bit 0001: 2 Stop Bits	0000	*2*3
13-3	Parity Selection	0000: Without Parity 0001: With Even Parity 0002: With Odd Parity	0000	*2*3
13-4	Data Format Selection	0000: 8-Bits Data 0001: 7-Bits Data	0000	*2*3

14- Motor Autotune Parameters

Function Code No.	Description	Range/Code	Factory Setting	Remarks
14-0	Stator Resistance (Ohms)	----		*3*5
14-1	Rotor Resistance (Ohms)	----		*3*5
14-2	Equivalent Inductance (mH)	----		*3*5
14-3	Magnetizing Current (Amps AC)	----		*3*5
14-4	Ferrite Loss Conductance (gm)	----		*3*5

15- Drive Status and Function Reset

Function Code No.	Description	Range/Code	Factory Setting	Remarks
15-0	Drive Horsepower Code	(See page 53)		*3
15-1	Software Version	----	----	*3
15-2	Fault Jog (Last 3 Faults)	(See page 53)	----	*3
15-3	Accumulated Operation Time (Hours)	0 to 9999	----	*3
15-4	Accumulated Operation Time (Hours X 10000)	0 to 27	----	*3
15-5	Accumulated Operation Time Mode	0000: Time Under Power 0001: Run Mode Time Only	0000	*3
15-6	Reset Drive to Factory Settings	1110: Reset for 50 Hz Motor Operation 1111: Reset for 60 Hz Motor Operation 1112: Reset PLC Program	0000	*4

Remarks:

***1 can be modified during operation.**

***2 cannot be modified during communication.**

***3 do not change while making factory setting.**

***4 as parameter related to factory setting.**

***5 the parameter will be changed by replacing model.**

***6 only available in V/F mode.**

***7 only for version 2.3 and above.**

***8 only for version 2.4 and above.**

***9 for 15HP of 220V class and 20HP of 440V class above**

3.4 Parameter function description

3.4.1 Parameter Group 0: Drive Operation Mode

0-00: Control Mode
0000: Vector mode (General Mode)
0001: Vector mode (VT Mode)
0002: V/F mode

Selects the most suitable vector control mode or V/F mode according to the load characteristics.

1. Vector (general mode) is intended to control the general load or rapidly-changed torque load.
2. Vector (VT mode) is suitable for Blower/ Pump and HVAC load. motor's magnetic current will vary according to the torque, which will reduce the current to save energy.
3. If V/F mode is selected, set parameter group10 to comply with the load features.

0-01: Motor Rated Voltage (VAC)
0-02: Motor Rated Current (A)
0-03: Motor Rated Power (kW)
0-04: Motor Rated Speed (RPM)
0-05: Motor Rated Frequency (Hz)
0-06: Motor Parameter Auto Tuning
0000: Disabled 0001: Enabled

It is necessary to enter nameplate and autotuning data as long as vector mode is selected to change the motor.

Autotuning: firstly enter the data for 0-01 to 0-05 according to the nameplate after power off, then set 0-06=0001 and perform autotuning; The internal data detected will be automatically written to parameter group 14 when the display shows "End".

Example, if the motor rated speed is 1700 rpm, please set 0-04 to 17.0

PRECAUTION: 1. The motor parameter autotuning covers stationary autotuning. During motor autotuning, the motor does not rotate, and the keypad display shows -AT-.

2. During motor parameter autotuning, the input signal in the control circuit is invalid.

3. Before motor parameter autotuning, please confirm the stop state of the motor.

4. The motor parameter autotuning is only available for vector control mode (0-00=0000 or 0-00=0001).

0-07 AC Line Input Voltage (Volts AC)
220V series: 170.0 to 264.0
440V series: 323.0 to 528.0

To make sure of the voltage level of the VSD, enter the actual on-site voltage value.

Parameter Group 1 - Start/Stop and Frequency Control Modes

1-00: Run Command Source Selection
0000: Keypad
0001: External terminal control
0002: Communication control
0003: Built-in PLC

1. 1-00=0000 the VSD is controlled by the keypad.
2. 1-00=0001 the VSD is controlled by the external terminals, and the Emergency Stop key does work. (Refer to 1-03 description).

NOTE: 1-00=0001, please refer to parameter group 2-00, 2-01, 2-02 and 2-03 for a detailed description of how to ensure personal and machine safety.

3. 1-00=0002 the VSD is communication controlled.
4. 1-00=0003 the VSD controlled by the built-in PLC, and 1-06 preset value is invalid.

1-01: Operation modes for external terminals
0000: Forward/stop-reverse/stop
0001: Run/stop-forward/reverse
0002: 3-wire control mode -run/stop

1. When operation command 1-00=0001 (external terminal), 1-01 is valid.
2. When operation command 1-00=0001 (external terminal control), the emergency stop button for is available. (Refer to 1-03 for detailed description).
3. If both forward and reverse commands are ON this will be treated as STOP.

1-01=0000, Control mode is as below:

(1) Input signal is NPN

(2) Input signal is PNP

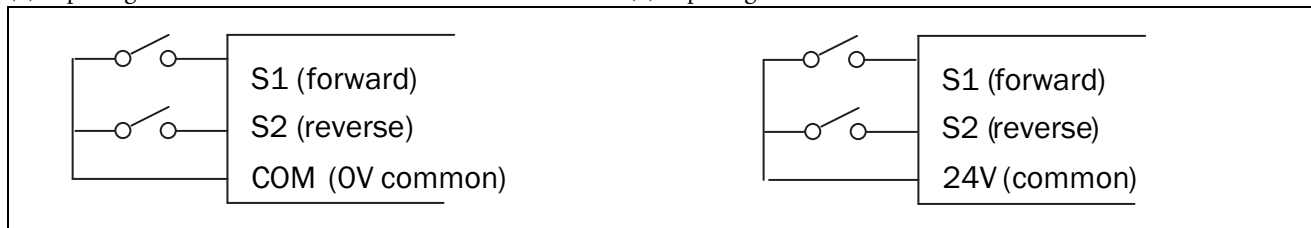

1-01=0001, Control mode is as below:

(1) Input signal is NPN(2) Input signal is PNP



1-01=0002, Control mode is as below:

(1) Input signal is NPN(2) Input signal is PNP

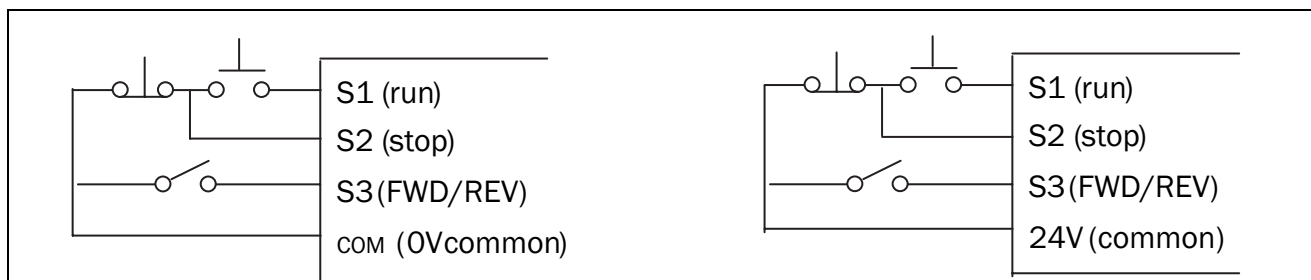

NOTE: If 3-wire control mode is selected, the terminal S3 is not controlled by 5-02.

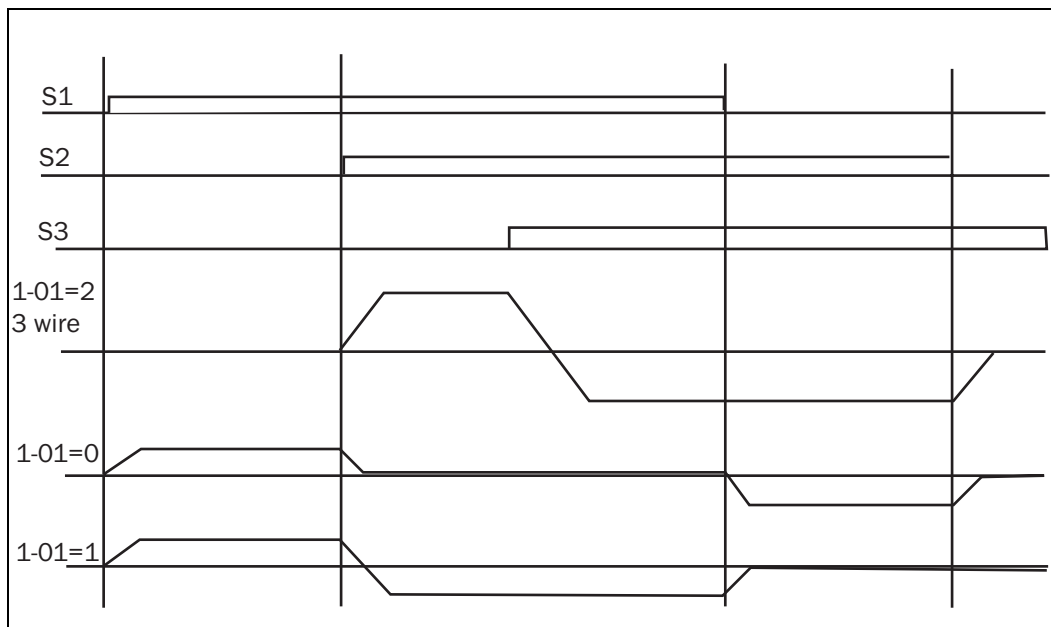

1-02=0001, the reverse command is unavailable.

NOTE: 1-02=0001, the reverse command is unavailable.

1-02: Prohibition of Reverse Operation
 0000: Enable Reverse Command
 0001: Disable Reverse Command

1-03: Keypad Stop Button
 0000: Stop Button Enable
 0001: Stop Button Disable

1-03=0000, the STOP key is available for controlling the stopping of the VSD.

NOTE: 1-03=0001 is valid only for 1-00=0001 and 0002,

1-04: Starting Method Selection

0000: Normal Start
0001: Enable Speed Search

1. 1-04=0000: When starting, the VSD accelerates from 0 to target frequency in the set time.
2. 1-04=0001: When starting, the VSD accelerates to target frequency from the detected motor speed.

1-05: Stopping Method

0000: Controlled Deceleration-to-Stop with DC Injection Braking (Rapid Stop)
0001: Free run stop

1. 1-05=0000: the VSD will decelerate to 0Hz in preset deceleration time after receiving the stop command.
2. 1-05=0001: the VSD will stop output when it receives the stop command. The motor will use inertia to free run to stop.

1-06: Frequency Command Source Selection

0000: Set the frequency with the keypad
0001: Potentiometer on the keypad
0002: External Analogue Signal Input or Remote Potentiometer
0003: Up/Down Frequency Control using MFIT (S1-S6)
0004: Communication Setting Frequency
0005: Impulse frequency (S5) setting frequency (ver 2.3)

1. 1-06=0001, if one of the parameter in group 5-00 to 5-06 is set to 16 and multifunction terminal is OFF, the frequency is set by the KNOB (VR for principal speed) on the keypad. While the multifunction is ON, the frequency is set by analogue signal (auxiliary speed) on terminal block (TM2).
2. 1-06=0002, if one of the parameter in group 5-00 to 5-06 is set to 16 and the multifunction terminal is OFF, the frequency is set by analogue signal (principal speed) on terminal block (TM2). While the multifunction is ON, the frequency is set by the KNOB (VR for auxiliary speed) on the keypad.
3. Please refer to the description of parameter group 5-00 to 5-06 (multifunction input terminals) for the function of the Up/Down terminal.
4. The priority for reading frequency is PLC frequency control >traverse run >Jog> preset speed> on the keypad or Up/Down keys or communication control.
5. Impulse frequency command input source should be set for S5 terminal and needs to coordinate with the 5-10

frequency exchange times ratio. For example, the input value for S5 is 4 KHz, 5-10 is 1.500 times, and the output frequency is $40.00 \times 1.5 = 60.00$ Hz. 5-04(S5) should be set to 19.

1-07: Keypad Operation using the up/down keys in Run Mode.

0000: "Enter" must be pressed after frequency change with the up/down keys on the keypad.

0001: Frequency will be changed directly when the up/down keys are pressed.

3.4.2 Parameter Group 2 - Manual/ Automatic Restart Modes

2-00: Momentary Power Loss and Restart
 0000: Momentary Power Loss and Restart Disable
 0001: Momentary Power Loss and Restart Enable
 0002: Momentary Power Loss and Restart Enable while CPU is Operating.
 2-01: Momentary Power Loss Ride-Thru Time (sec): 0.0 - 2.0 seconds.

1. As starting the power supply for the other load results in the voltage going down to less than the under voltage level, the VSD will stop output at once. If the power supply recovers in the 2-01 preset time, it will start a speed search start tracing from the trip frequency, or the VSD will trip with "LV-C" displayed.
2. The allowable power time loss varies from model to model. The range is from 1 to 2 seconds.
3. 2-00=0000: if power is lost, the VSD will not start.
4. 2-00=0001: if the loss time is less than the value of 2-01, the VSD will Spin Start in 0.5 seconds as the power supplied and restart times are infinite.
5. 2-00=0002: if the power lost lasts for long time and is before the VSD loses the control power for the CPU, the VSD will restart according to the 1-00 and 2-04 settings and the status of the external switch when the power is turned back on.

NOTE: 1-00=0001, 2-04=0000, 2-00=0001 or 0002 after power loss for a long time, turn OFF the power and power switches to prevent personal injury and machine damage when the power is turned back on.

2-02: Auto restart Delay Time: 0 to 800.0 seconds
 2-03: Number of Auto restart Attempts: 0 to 10 times

1. 2-03=0: the VSD will not auto restart if it was tripped accidentally.
2. 2-03>0, 2-02=0: the VSD will conduct SPEED SEARCH 0.5 seconds after it is accidentally tripped. The motor will use inertia to run to the frequency at the trip stop, then accelerate or decelerate time to target frequency according to its setting.
3. 2-03>0, 2-02>0: the output will be stopped for a period which is determined by 2-02 after an accidental trip. A speed search is then performed to find the target frequency.

4. As the VSD is set to braking deceleration or DC braking, it will not restart after accidental trip.

2-04: Start Method:
 0000: Enable Speed Search
 0001: Normal Start

1. 2-04=0000: the VSD will detect motor speed and accelerate the setting frequency via speed search enable.
2. 2-04=0001: the VSD will accelerate the motor speed from stop (zero speed) to setting frequency.

2-05: Direct running after power up:
 0000: Enable Direct Running After Power Up
 0001: Disable Direct Running After Power Up



WARNING: 1.) 2-05=0000 and the VSD is set to external terminal controlled (1-00=0001). If the run switch is ON as power is supplied, the VSD will auto start. It is recommend that you turn off the power switch and run switch to avoid personal injury or machine damage when the power turned back on.

2.) 2-05=0001 and the VSD is set to external terminal controlled (1-00=0001). If the run switch is ON as power is supplied, the VSD will not auto start and STP1 will flash. It is necessary to OFF the run switch and then ON again to start normally.

2-06: Delay-ON Timer (seconds): 0 to 300.0 seconds

When power is on and 2-05=0000, the VSD will perform auto restart within the setting delay time.

2-07: Error reset mode setting
 0000: Enable Reset Only when Run Command is Off
 0001: Enable Reset when Run Command is On or Off

2-07=0000 when the VSD detects the accidental trip, please turn off the Run switch to perform reset, or restarting does not work.

2-08: Kinetic Energy Back-up Deceleration Time: 0.00 to 25.00 seconds

- 2-08=0 KEB function disable
- 2-08≠0 KEB function enable

Example: 220 V system

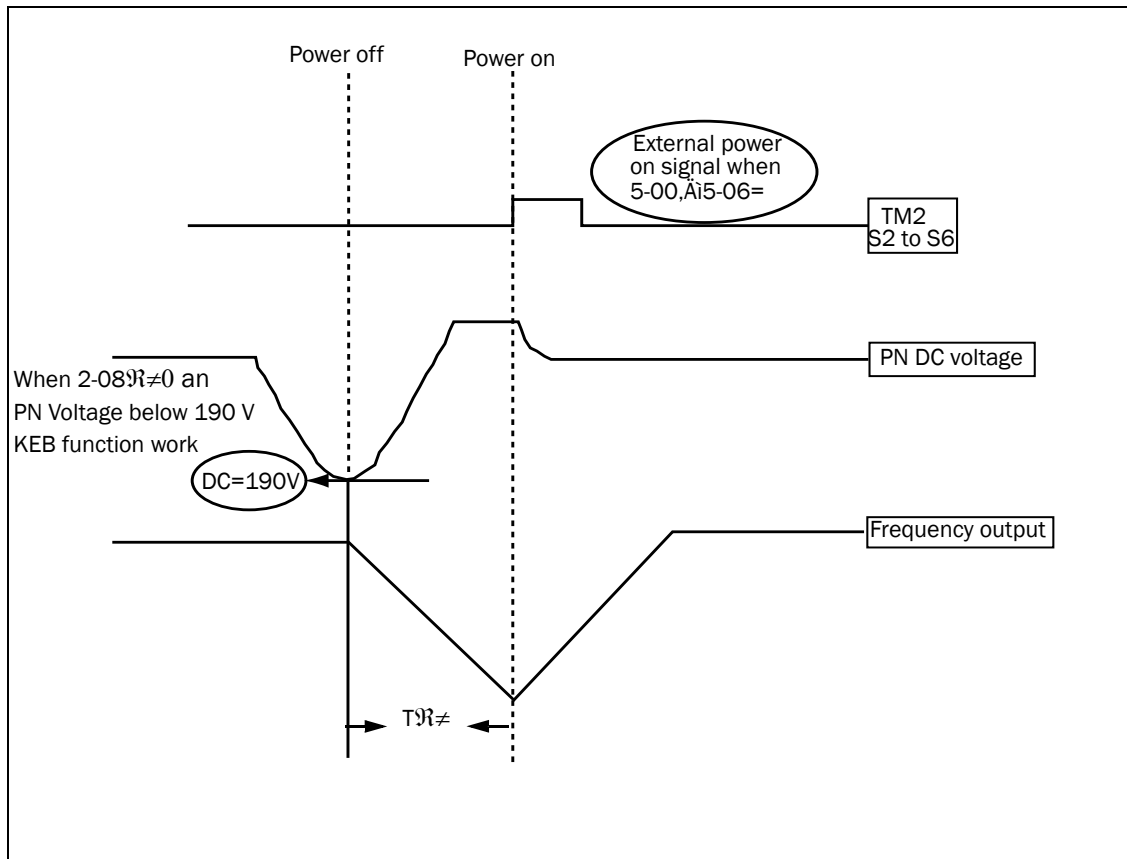

NOTE: 1. For 2-08 Function.

2. When the power is off CPU detect the DC Voltage. KEB function is enabled when DC Voltage lower than 190V/220V system or 380V/440V system.

3. When the KEB function is enabled, the VSD decelerates to zero using 2-08, and the VSD stops.

4. If the power on signal enabled during the KEB function, the VSD accelerates to its original frequency.

NOTE: When 3-01=0 Hz and frequency command is 0 Hz, the VSD will stop at 0 speed.

When 3-01 > 0 Hz and frequency command is 3-01, the VSD will output the 3-01 preset value.

3.4.3 Parameter Group 3 - Operating Parameters

3-00: Frequency Upper limit (Hz): 0.01 to 650.00
 3-01: Frequency Lower limit (Hz): 0.01 to 650.00

3-02: Acceleration Time #1 (s): 0.1 to 3600.0
 3-03: Deceleration Time #1 (s): 0.1 to 3600.0
 3-04: S Curve of First Acceleration Stage (s): 0.0 to 4.0
 3-05: S Curve of Second Acceleration Stage (s): 0.0 to 4.0
 3-06: Acceleration Time #2 (s): 0.1 to 3600.0
 3-07: Deceleration Time #2 (s): 0.1 to 3600.0
 3-08: Jog Acceleration Time (s): 0.1 to 25.5
 3-09: Jog Deceleration Time (s): 0.1 to 25.5

When 3-01 > 0 Hz and frequency command

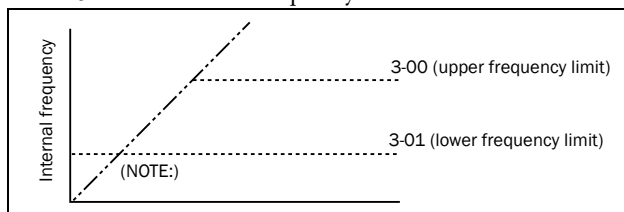

1. Formula for calculating acceleration and deceleration time: The denominator is base on the rated frequency of motor.

$$\text{Acceleration time} = 3-02 \text{ (or } 3-06) \times \frac{\text{Preset frequency}}{0.05}$$

$$\text{Deceleration time} = 3-03 \text{ (or } 3-07) \times \frac{\text{Preset frequency}}{0.05}$$

- When 5-00 – 5-06 is set as 06 (the second acceleration and deceleration time), the first acceleration/ deceleration/ S-curve or the second acceleration/ deceleration/ S-curve will be selected with off or on the external input terminal.
- When 5-00 – 5-06 is set to 05 (Jog), Jog run is controlled by external terminals. The acceleration and deceleration

action will be at Jog acceleration and deceleration time.

- When 5-00 – 5-06 is set as 05 (Jog) and 06 (acceleration and deceleration time toggle), change the acceleration and deceleration time with ON on the external terminals. Here is a list of setting:

Function	Acc/ Dec time 1 (3-02/3-03)	Acc/ Dec time 2 (3-06/3-07)	JOG Acc/Dec time (3-08/3-09)
preset value	1-06 determines the output frequency	1-06 determines the output frequency	Run at 6-01Jog frequency
5-00 to 5-05=06 Jog command	Off	Off	On
5-00 to 5-06=04 Toggle Acc/Dec time.	Off	On	Off

- When S-curve time (3-04/3-05) is set as 0, the S curve is useless. The line shows acceleration and deceleration.
- When S-curve time (3-04/3-05) is greater than 0, the acceleration and deceleration action is as per the following diagram.
- Regardless of the stall prevention period, actual acceleration and deceleration time = preset acceleration / deceleration time + S-curve time. For example: acceleration time = 3-03+3-04.
- During the acceleration and deceleration process, there may be residual error in acceleration and deceleration toggling. Please set the S-curve time as 0 (3-04/3-05) if you need to toggle acceleration and deceleration time during the acceleration/deceleration process.

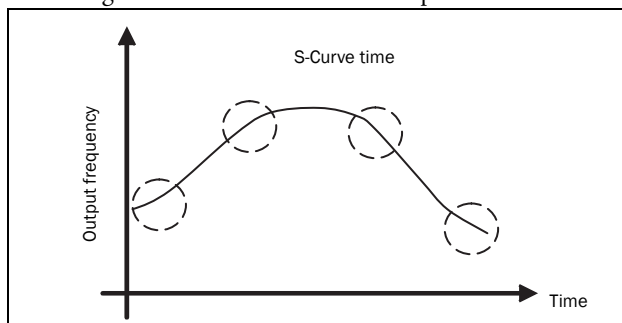

- 3-10: DC Injection Brake Start Frequency (Hz): 0.1 to 10.0
- 3-11: DC Injection Brake Level (%): 0.0 to 20.0
- 3-12: DC Injection Brake Time (s): 0.0 to 25.5

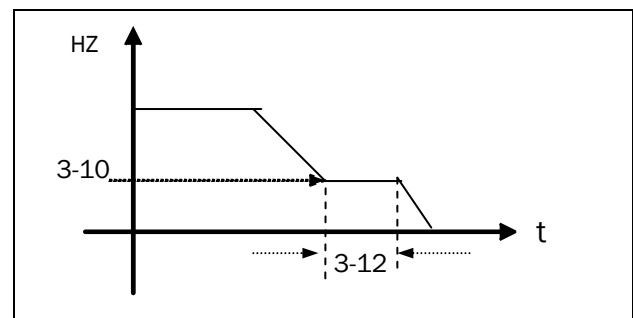

3-12 / 3-10 is the action time and start frequency of DC braking, as graph below:

The upper setting of 3-11 will be corrected 20.0 after manual V2.3.

- 3-13: Skip Frequency #1 (Hz): 0.00 to 650.00
- 3-14: Skip Frequency #2 (Hz): 0.00 to 650.00
- 3-15: Skip Frequency #3 (Hz): 0.00 to 650.00
- 3-16: Skip Frequency Bandwidth (\pm Hz): 0.00 to 30.00

Example: 3-13 is set to 10.0 Hz / 3-14 to 20.0 Hz / 3-15 to 30.0 Hz / 3-16 as 2.0Hz

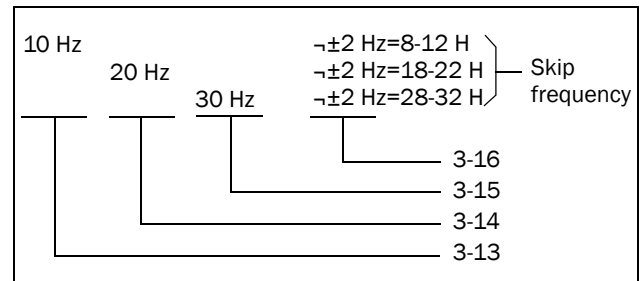

3-17: Parameter lock function
 0000: Enable all Functions
 0001: 6-00 to 6-08 cannot be changed
 0002: All Functions Except 6-00 to 6-08 cannot be changed
 0003: Disable all Functions

3-18: Copy Unit
 0000: Disable
 0001: VSD to Copy Unit
 0002: Copy Unit to VSD
 0003: Verify

1. 3-18=0000: VSD can not copy parameter.
2. 3-18=0001: Copy the VSD parameters to module.
3. 3-18=0002: Copy the module parameters to VSD.
4. 3-18=0003: Copy the parameters to VSD or module to mutually verify the parameters.

NOTE: The copy function is available for the models with same capacity.

3-19: Fan Running Control
 0000: Auto (Depend on temp.)
 0001: Operate while in RUN Mode
 0002: Always Run
 0003: Always Stop

1. 3-19=0000: The fan runs as the VSD senses temperature rises. Extend the service period accordingly.
2. 3-19=0001: The fan runs while the VSD is running.
3. 3-19=0002: The fan runs continuously regardless of what the VSD is doing.
4. 3-19=0003: The fan always stops regardless what the VSD is doing.

3-20: Energy Saving Mode Operation
 0000: Disabled
 0001: Controlled by MFIT at Set Frequency
 3-21: Energy saving operation gain (%): 0-100

1. While operation, FAN, PUMP or other heavy inert loads which need greater starting torque, do not need such high torque. As a result, use setting 3-20 to save energy by reducing the output voltage.
2. 5-00 to 5-06 (Multifunction input terminal) set to 10 in order to save energy.
3. 3-20=0001, if the multifunction terminal is set to 10 (energy saving control terminal), the output voltage will gradually decline to "original voltage" x "3-21" preset value when the terminal is ON. The output voltage will rise to the original voltage when the terminal is OFF.

NOTE:1. The declining and rising voltage speeds for energy saving are same as those for SPEED SEARCH.

2. Energy saving mode is only available under V/F mode. (0-00=0002).

3-22: Carrier Frequency (KHz): 2 to 16

3-22	Carrier Frequency	3-22	Carrier Frequency	3-22	Carrier Frequency	3-22	Carrier Frequency
2	2KHz	6	6KHz	10	10KHz	14	14KHz
3	3KHz	7	7KHz	11	11KHz	15	15KHz
4	4KHz	8	8KHz	12	12KHz	16	16KHz
5	5KHz	9	9KHz	13	13KHz		

NOTE: The external electronic components may experience interference or, more seriously, motor vibration if the high carrier frequency waveform is turned off, even though the VSD is very quiet during operation. As a result, it is necessary to regulate the carrier frequency.

3-23: Centre Frequency (CF) of Traverse Run (%): 2 to 16
 3-24: Amplitude (%) 0.1 to 20.0
 3-25: Amplitude Drop(%): 0.0 to 50.0
 3-26: Acceleration Time (s): 0.5 to 60.0
 3-27: Deceleration Time (s): 0.5 to 60.0
 3-28: Deviated traverse (X upper deviation) (%): 0.0 to 20.0
 3-29: Deviated traverse (Y lower deviation (%): 0.0 to 20.0)

Traverse Run is defined as adding a triangle wave to the basic operation frequency of VSD output frequency at the preset acceleration and deceleration time. The motion is as per the graph below:

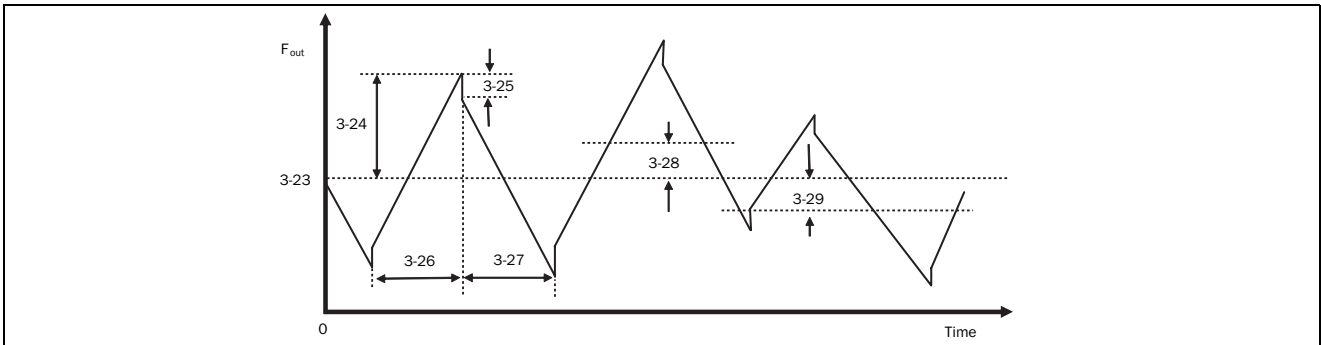

3-23: Traverse Run Centre frequency (%)

3-24: Amplitude (%)

3-25: Amplitude Drop (%)

3-26: Acceleration Time (s)

3-27: Deceleration Time (s)

3-28: Deviated traverse (X upper deviation)

3-29: Deviated traverse (Y lower deviation)

1. The traverse run is available when the run command and the terminal (5-00 to 5-05=0025) for such operation both ON. When the VSD is operating, the traverse run

is ready when the VSD output frequency reaches centre frequency (3-23). During acceleration to centre frequency, the acceleration time is at the original preset value (3-02/3-06). When the traverse run is OFF or the VSD is OFF, the deceleration time is also at the original preset value (3-03/3-07). However, during traverse running, the VSD is at traverse run acceleration time (3-36) and deceleration time (3-27). The motion is as the following diagram:

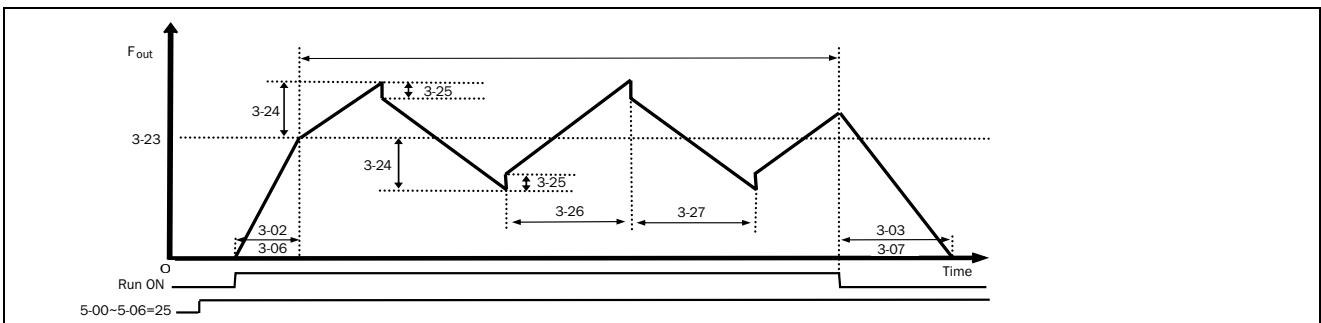

2. During traverse run, the centre frequency could be controlled by the multifunction input terminals. However, the X upper deviation and Y lower D deviation cannot

be entered at the same time. If they are entered at the same time, the VSD will maintain the original centre frequency. The motion is as per the graph below:

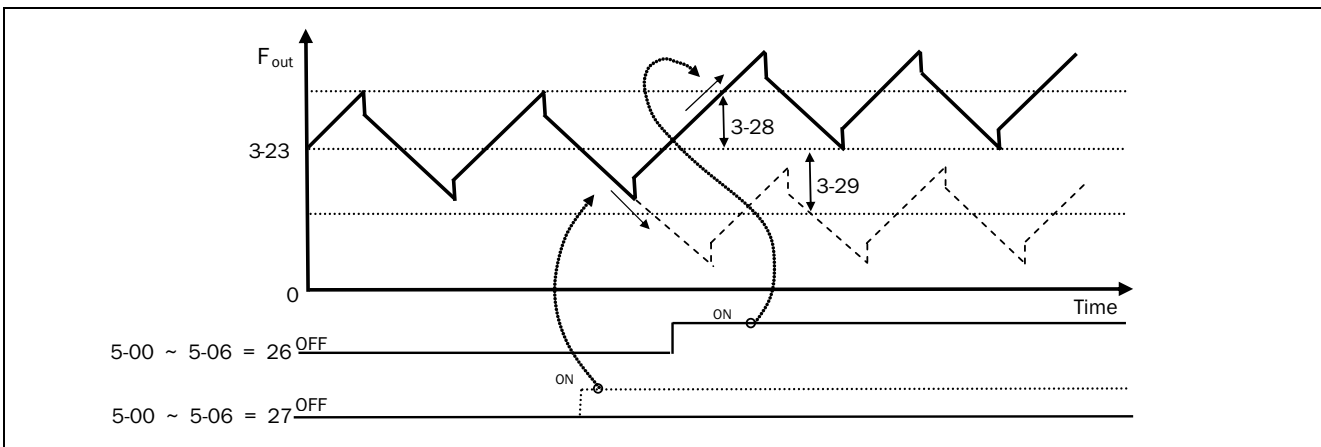

3. The stall prevention is idle during the acceleration and deceleration time of traverse run. But it is valid during first acceleration to centre frequency process when the traverse run function is OFF or the VSD is in deceleration time after the STOP command is received.

4. The frequency range of the traverse run is restricted by the VSD's upper and lower frequency limits, i.e. if the (centre frequency + amplitude) is greater than the upper limit, it will operate at the upper frequency limit. And if (centre frequency - amplitude) is less than the lower limit, vice versa.

5. During traverse run, not all the preset values, such as centre frequency, amplitude, amplitude drop, acceleration time, deceleration time, traverse run upper deviation and lower deviation, can be modified. The modified acceleration and deceleration time is priority for the original one, but not traverse run acceleration and deceleration time. The motion is as per the graph below:
6. The stall prevention protection is unavailable during traverse run acceleration and deceleration time. Therefore this must be taken into consideration when designing equipment so that the actual system capacity complies with the proper VSD capacity.
7. Centre frequency = 3-23*max. frequency (3-00)
 Amplitude = 3-24*centre frequency
 Acceleration/Deceleration time = amplitude acceleration/deceleration time
 Amplitude Drop = 3-25*amplitude

Deviated traverse (X upper deviation) = 3-28*traverse run centre.

Deviated traverse (lower deviation) = 3-29* traverse run centre.

If you want to change the max. frequency of 3-00, reset 3-23 to 3-29 values where necessary.

3.4.4 Parameter Group 4 - Digital Display Operation Mode

4-00: Motor Current Display Selection:
 0000: Disable Motor Current Display
 0001: Enable Motor Current Display

4-01: Motor Voltage Display Selection:
 0000: Disable Motor Voltage Display
 0001: Enable Motor Voltage Display

4-02: DC Bus Voltage Display Selection:
 0000: Disable Bus Voltage Display
 0001: Enable Bus Voltage Display

4-03: PLC Status Display Selection:
 0000: Disable PLC Status Display
 0001: Enable PLC Status Display

This function is available for the LCD keypad, but not for the LED one.

4-04: Custom Units (Line Speed) Value: 0-9999

The max preset line value of 4-04 is equal to the rated frequency (0-05) of the motor. For instance, given line speed 1800 is equal to display 900 when output is 30 Hz while the operation frequency is 60 Hz.

4-05: Custom Units (Line Speed) Display Mode
 0000: Drive Output Frequency is Displayed
 0001: Line Speed is Displayed in Integers (xxxx)
 0002: Line Speed is Displayed to One Decimal Place (xxx.x)
 0003: Line Speed is Displayed to Two Decimal Places (xx.xx)
 0004: Line Speed is Displayed to Three Decimal Places (x.xxx)

The preset frequency is displayed when the VSD stops while the operation line speed is displayed when the VSD is running.

4-06: PID Feedback Display
 0000: Disable
 0001: Enable

Keypad displays PID feedback value:

Parameter 5-05=20 (That is, S6 is set as the PID feedback analogue terminal, refer to PID), 11-0=1 (PID is enabled), and 4-06=1 (Display S6 as PID analogue feedback value 0-100, the formula as follows:)

If feedback signal is 0-10V, (12-6=0000), keypad display value = (S6/10V)*100.

If feedback Signal is 4-20mA, (12-6=0001), keypad display value = (S6/20mA)*100.

NOTE: Please press the  Key to switch between the output frequency and PID feedback value.

NOTE: The VSD displays XXXF as Running, while XXXr as Stop.

3.4.5 Parameter Group 5 - Multifunction Input Terminals (MFIT)

Multifunction input terminals (TM2 S1-S6/AIN) controlling:

5-00 to 06

- 000: Forward/Stop Command *1
- 0001: Reverse/Stop Command *2
- 0002: Preset Speed # 1 (6-02)
- 0003: Preset Speed # 2 (6-03)
- 0004: Preset Speed # 3 (6-05) *3
- 0005: Jog
- 0006: Acc/Dec time # 2
- 0007: Emergency Stop Contact A
- 0008: Base Block
- 0009: Speed Search Stop
- 0010: Energy Saving
- 0011: Control Signal Selection
- 0012: Communication Control Signal Selection
- 0013: Acc/Dec Disabled
- 0014: Up Command
- 0015: Down Command
- 0016: Principal/Auxiliary Speed
- 0017: PID Function Disabled
- 0018: Reset
- 0019: Encoder Input Terminal (Terminal S5)
- 0020: PID Feedback Signal A12 (Terminal S6)
- 0021: AI2 Bias Signal 1 Input (Terminal S6)
- 0022: AI2 Bias Signal 2 Input (Terminal S6)
- 0023: Analogue Input Terminal AIN
- 0024: PLC Application
- 0025: Traverse Run
- 0026: Traverse Run Upper Deviation
- 0027: Traverse Run Lower Deviation
- 0028: Power Source Detect for KEB Function
- 0029: Emergency Stop Contact B

A. The terminals S1-AIN on terminal block (TM2) are multifunction input terminals. The above 30 functions can be set in these terminals.

B. Function Description for 5-00 to 06:

1. 5-00 to 06=0/1 (Forward/Reverse/Stop)
When forward command is ON, the VSD runs and stops when it is OFF. The 5-00 factory setting is forward. When reverse command is ON, the VSD runs and stops when it is OFF. The 5-01 factory setting is reverse.
2. 5-00 to 06=2-4 (Preset speed 1 to 3)
When the external multifunction input terminals are ON, the VSD operates for the preset time, and the duration is determined by the time the terminal is ON. The corresponding frequency parameter is illustrated below:
3. 5-00 to 06=5 (Jog)
To select Jog operation the external input terminals must be ON. The VSD operates for the Jog acceleration and deceleration time. The corresponding frequency parameter is illustrated below:

The priority order of frequency: Jog SpeedPreset SpeedKeypad frequency or external frequency signal

Multifunction terminal 3 Preset value=04	Multifunction terminal 2 Preset value=03	Multifunction terminal 1 Preset value=02	Jog Command terminal Preset value=05	Output frequency preset value
0	0	0	0	6-00
X	X	X	1	6-01
0	0	1	0	6-02
0	1	0	0	6-03
0	1	1	0	6-04
1	0	0	0	6-05
1	0	1	0	6-06
1	1	0	0	6-07
1	1	1	0	6-08

4. 5-00 to 06=6 (toggle acceleration and deceleration time)
On the external input terminal, to select the acceleration

1/ deceleration 1/ S-curve 1 or acceleration 2/ deceleration 2/ S-curve 2.

5. 5-00 to 06=7 /29: External emergency stop contact A or B. The VSD will decelerate to stop and flash E.S when the emergency stop signal is received regardless of the 1-05 setting. After this signal is released, turn OFF the operation switch then turn it ON or press the Operation Key, the VSD will restart from the start frequency. If the emergency signal was released before the VSD came to complete stop, the VSD will still perform an emergency stop. The 8-02/03 determines the action of the error terminal. When 8-02/0=0 the error terminal does not act when the external emergency signal is received. When 8-02/03=9, the error terminal does act when an emergency signal is received.
6. 5-00 to 06=8: Base Block
The VSD stops output when it receives a STOP command, and the motor Free-Run stops.
7. 5-00 to 06=9: Speed Search Stop
When starting, the VSD detects the present speed of the motor first, then the VSD accelerates from the present speed to preset speed.
8. 5-00 to 06=10: Energy-saving operation
While in operation FAN, PUMP or other heavy inert loads which need greater start torque, do not need such high torque. As a result, save energy by reducing the output voltage. The output voltage gradually declines when the multifunction terminal is ON. It will gradually

increase (to the original voltage) when the multifunction terminal is OFF.

NOTE: The acceleration and deceleration speed of energy saving operation is the same as the speed of SPEED SEARCH.

9. 5-00 to 06=11: Control signal switch
External switch terminal is OFF: 1-00/01 determines the operation signal and frequency signal.
External switch terminal is ON: Keypad controls the operation signal and frequency signal but not controlled by 1-00/01.
10. 5-00 to 06=12: The VSD switch controlling communication.
External switch terminal is OFF: for communication, the master (PC or PLC) can control the VSD operation and frequency signal and allow the modification of parameters. The operation signals from the keypad and TM2 are idle. Furthermore, the keypad can only display the voltage, current and frequency; the parameters are readable but not writable, and Emergency Stop is valid. External switch terminal is ON: for communication, the VSD is controlled by the keypad regardless of the setting of 1-00/1-06 and master. In this situation, the master can still read and write the VSD parameters.

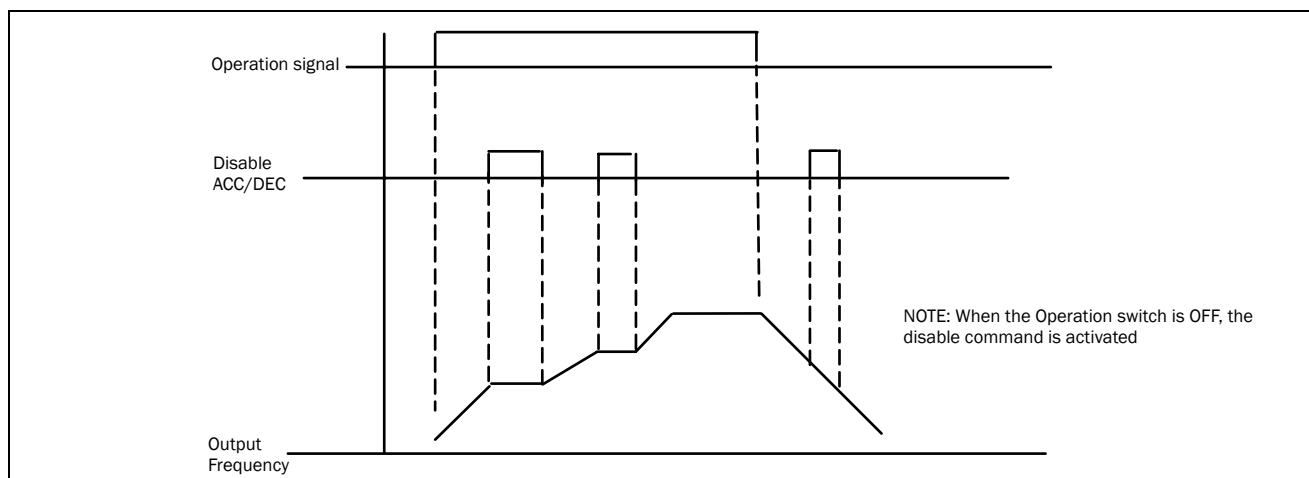

12. 5-00 to 06=14,15: Up / Down Function (actual acc/dec time is based on the setting):
 - (1) Please set 1-06=3 if you want to use the Up/Down function, and the other frequency signals are useless.
 - (2) Set 5-08=0 and 5-09=0, the VSD accelerates to the preset value of 6-00 when the operation terminal is ON. It then maintains the known speed. As the VSD receives the Up/Down command, it will accelerate / decelerate until the command is released. The VSD runs at the known speed. The VSD will either ramp stop or Free-Run stop, this is determined by the 1-05 setting as long as the VSD receives the STOP command. The stopping frequency will be stored in 6-00. The Up/Down key is invalid when the VSD stops. You need to use the keypad to modify the preset parameter.
 - (3) Set 5-08=1 and the VSD will operate from 0 Hz when the operation terminal is ON. The Up/Down

action is as per the description above. The VSD will ramp stop or free-run stop, which is determined by the 1-05 setting when it receives the Stop Command and go back to 0 Hz. The next operation will start at 0 Hz.

- (4) If the UP/Down signal cannot act simultaneously.
- (5) 5-09 0, the VSD will accelerate to the setting of 6-00 and maintain this speed. When the Up/Down terminal is ON, the setting frequency is the present value of 6-00±5-09, and the VSD will accelerate/decelerate to frequency 6-00. The upper frequency limit and lower frequency limit also restrict the operation. If the Up/ Down signal is maintained for 2 seconds, the VSD will begin to accelerate/decelerate. If 5-09=0, the operation is the same, until the Up/ Down signal stops. Please refer to the time diagram for 5-09.

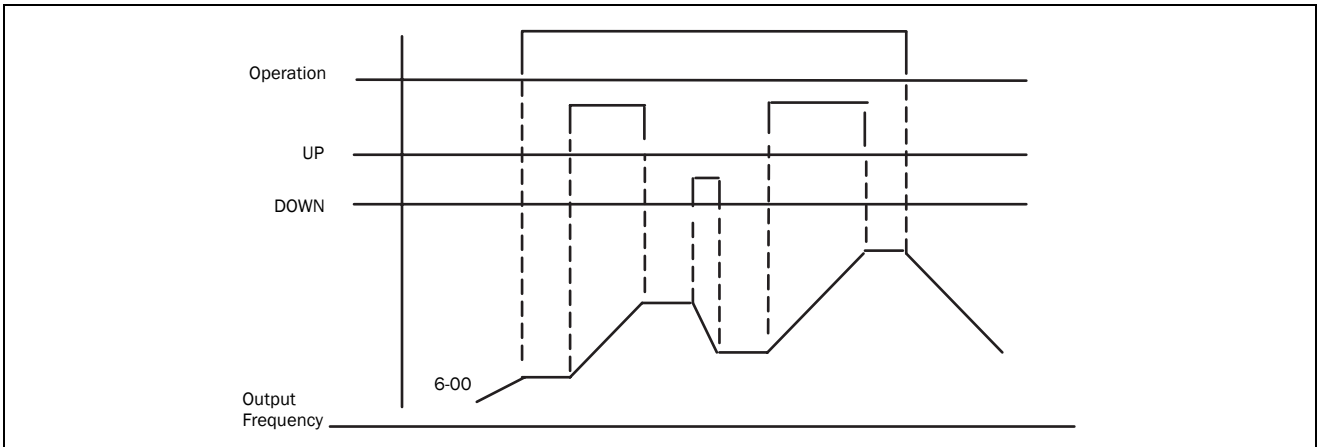

13. 5-00 to 06=16 Principal/Auxiliary speed toggle
Multifunction terminal = OFF, the frequency is set by Master Speed, whereas, Multifunction terminal = ON, the frequency is set by Auxiliary Speed.
Example. 1-06=0001, the master speed is the VR on the keypad and the auxiliary speed is the analogue signal on the TM2 terminal block.
14. 5-00 to 06=17 (PID Function Disable)
The PID Function Disable is ON. PID is not controlled by 11-0, while OFF, it is controlled by 11-0.
15. 5-00 to 06=18 (Reset Command)
The Reset command is the same as when the Reset Key on the panel is ON. The command is OFF, and the VSD does not respond. The factory setting of 5-05 is Reset command.
16. 5-04=19 (Encoder Input terminal)
The multifunction terminal S5 is set to 19, which means it is the input terminal for the PLC program Encoder.
17. 5-05=20 (PID feedback input terminal)
The multifunction terminal S6 = 20, which means the PID feedback input terminal and 0-10V (0-20 mA) or 2-10V (4-20mA) is available by setting 11-0.
18. 5-05=21 /22 (Bias signal 1/2 input)
To regulate the Offset of the Keypad VR or AIN analogue input, only a signal of 0-10V (0- 20 mA) or 2-10V (4-20mA) is available.

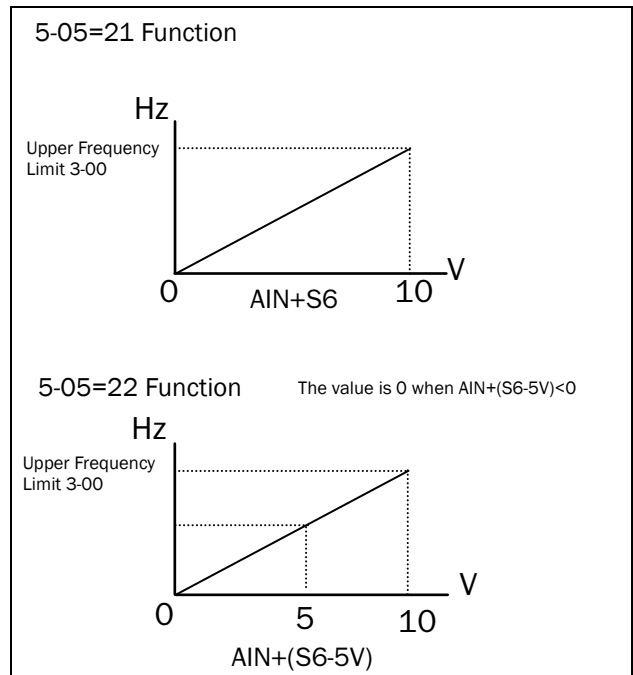

19. 5-06=23 (Analogue input AIN)
The multifunction terminal AIN = 23. The action is provided for setting the frequency.
20. 5-00-06=24 (PLC Application)
The multifunction terminal S1-AIN = 24, which means the terminal is for PLC application. The terminal is provided for the PLC program input.
21. 5-00-06=25 (Traverse Run); 5-00-06=26 (Upper Deviation Traverse); 5-00-06=27 (Lower deviation Traverse).
Refer to 3-23-3-29 for a detailed motion description.
22. 5-00-06=28 (Power Source Detect for KEB Function)
Please refer to the description of 2-08.

Digital/Analogue input signal scan times:

5-07: Multifunction terminal S1-S6 and AIN signal confirm the scan times (ms X 4), 1 to 100 times

1. TM2 terminal used for scanning. If the same signals are continuously entered for N times (i.e. scan times), the VSD will treat the signal as normal. If the scan times are less than N, the signal will be audible.
2. Each scan period is 4ms.
3. The user can specify the duration of the scan times interval according to the noise environment. If the noise is serious, increase the value of 5-07, but the response speed will be slowed down.

NOTE: If the S6 and AIN are for a digital signal, the voltage level for a digital signal above 8 V is treated as ON, below 2 V is OFF.

Stop Mode Using MFIT:

5-08:

0000: When Up/Down is used, the preset frequency is held when the VSD stops, and the Up/Down is idle.

0001: When Up/Down is used, the preset frequency is reset to 0 Hz as the VSD stops.

0002: When Up/Down is used, the preset frequency is held when the VSD stops, and the Up/Down is available.

(1) Set 5-08=0, the VSD will accelerate to the speed of 6-00 as it receives the Run command and run at that speed. The VSD begins to accelerate (decelerate) as the Up (Down) terminal is energised. The VSD will hold the speed as the Up/Down command is released. When the Run Signal releases, the VSD will ramp stop or stop output (determined by the 1-05 setting). It will store the frequency when the operation signal disappears. Up/Down keys are idle when the VSD is at rest. The keypad allows you to modify the preset frequency (6-00). If 5-08=0002 the Up/Down is available when the VSD stops.

(2) Set 5-08=1, when the Run terminal is energised, the VSD operates from 0 Hz, the Function of Up/Down is the same as in the description above. When the Run signal is released, the VSD will ramp stop or stop output (determined by 1-05). And the VSD goes back to 0 Hz. The following operation will always begin from 0 Hz.

Step of Up/Down Function (Hz):

5-09: Up/Down (Hz) 0.00 to 5.00

There are two modes covered below:

(1) 5-09=0.00, the function is disable. The operation is just like the original one. When the UP terminal is ON, the frequency increases, and when the Down terminal is ON, the frequency decreases. (Refer to the following graph).

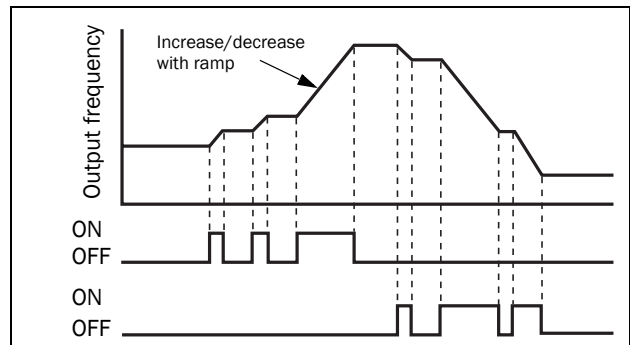

(2) 5-09=0.01 to 5.00, Up/ Down terminal ON, which is equivalent to increasing/decreasing the frequency of 5-09. If the held down for over 2 seconds, revive the original Up/Down mode (Please refer to the following diagram).

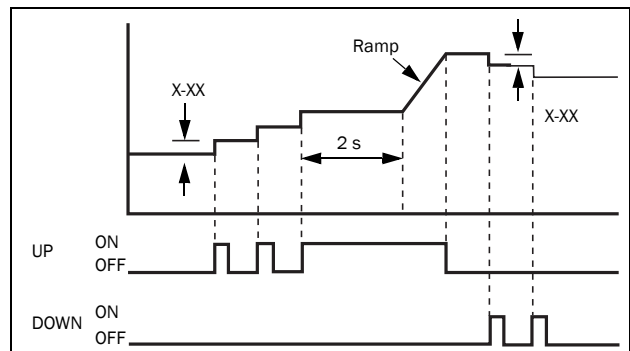

Encoder Impulse Ratio:

5-10 Impulse input frequency time ratio

When frequency source 1-06 is set as 0005, the impulse signal frequency will be according to this parameter to decide the real internal frequency of the VSD.

The internal calculation formula: Frequency = S5 (impulse frequency)*5-10 (times ratio)

For example, when the S5 impulse is 1KZ1000, and 5-10 is set to 1.50 times, the VSD frequency command is $1000 * 1.5 = 1500 = 15.00\text{Hz}$. The frequency accuracy of S5 is by based on 100; i.e. 1K (1000) present 10.00 Hz.

Reference Source 2:

5-11 Auxiliary frequency source can be selected

Example.

If the frequency source command is set as impulse command, (1-06=5).

If using master speed operation (5-00 to 5-06 set to 16 and the terminal is OFF), the frequency runs as impulse frequency.

If using auxiliary speed operation (5-00 to 5-06 set to 16 and the terminal is ON), the frequency should be decided by the 5-11 setting.

The action process is as follows:

5-11=0, frequency refer to 6-00.

5-11=1, frequency refer to the VR analogue signal on the keypad.

5-11=2, frequency refer to the VR analogue signal on TM2.

5-11= 3, frequency refer to the frequency value which is calculated by Up/Down on TM2.

5-11= 4, frequency refer to the input communication frequency.

3.4.6 Parameter Group 6 - Jog and Preset (MFIT) Speed Setting on Keypad

Jog and Preset (MFIT) Speed Setting on Keypad:
6-00 to 08: Set Jog and preset speed with Keypad

A. 5-00 to 06=2-4 (preset speed 1 to 3)

The external multifunction terminal = ON, the VSDVSD operates at preset speed. The operation time of the 8 stages

is based on the ON time of the terminal. Please refer to the corresponding parameters list:

B. 5-00 to 06=5 (Jog terminal)

The external multifunction terminal = ON, the VSD operates in Jog acceleration time/ Jog decelerate time/ON.

Function Code No.	Description	Range/Code
6-00	Keypad Frequency (Hz)	0.00 to 650.00
6-01	Jog Frequency (Hz)	0.00 to 650.00
6-02	Preset Speed #1 (Hz)	0.00 to 650.00
6-03	Preset Speed #2 (Hz)	0.00 to 650.00
6-04	Preset Speed #3 (Hz)	0.00 to 650.00
6-05	Preset Speed #4 (Hz)	0.00 to 650.00
6-06	Preset Speed #5 (Hz)	0.00 to 650.00
6-07	Preset Speed #6 (Hz)	0.00 to 650.00
6-08	Preset Speed #7 (Hz)	0.00 to 650.00

Priority in reading the frequency: Jog > Preset speed > Keypad frequency or external frequency signal.

Multifunction terminal3 Preset value=04	Multifunction terminal 2 Preset value=03	Multifunction terminal 1 Preset value=02	Jog Command terminal Preset value=05	Output frequency preset value
0	0	0	0	6-00
X	X	X	1	6-01
0	0	1	0	6-02
0	1	0	0	6-03
0	1	1	0	6-04
1	0	0	0	6-05
1	0	1	0	6-06
1	1	0	0	6-07
1	1	1	0	6-08

3.4.7 Parameter Group 7 - Analogue input signal operation mode

Analogue Input Signal Operation Mode: (The function is valid when 1-06==0002)

7-00: AIN Gain (%) 0 - 200

7-01: AIN Bias (%) 0 - 100

7-02: AIN Bias Selection:

0000: positive
0001: negative

7-03: AIN Slope:

0000: positive
0001: negative

7-04: AIN signal verification Scan Time (AIN, AI2) 1-100 (x 4ms)

7-05: AI2 Gain (%) (S6) 0 - 200

- 7-02=0: 0V (0mA) corresponding to lower frequency limit. 10V (20mA) corresponding to upper frequency limit.
- 7-02=1: 10V (20mA) corresponding to lower frequency limit 0V (0mA) corresponding to upper frequency limit.
- 12-6=0: 0-10V (0-20mA)
 $F = I*(3-00)/20$ $I >= 0SW2 =$ or $F = V*(3-00)/10$
 $V >= 0SW2 = V$
 = 1: 2-10V (4-20mA)
 $F = (I-4)*(3-00)/16$ $I >= 4SW2 =$
 $F = 0$ $I < 4$
 $F = (V-2)*(3-00)/8$ $V >= 2SW2 = V$ or
 $F = 0$ $V < 2$

The setting of figure 1: The setting of figure 2:

	7-00	7-01	7-02	7-03	7-05		7-00	7-01	7-02	7-03	7-05
A	100	50%	0	0	100%	C	100	50%	0	1	100%
B	100	0%	0	0	100%	D	100	0%	0	1	100%

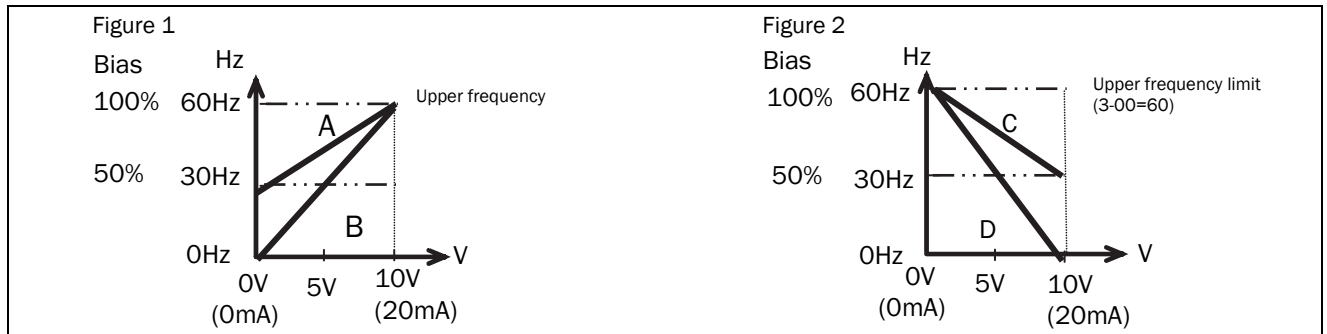

The setting of figure 3:

The setting of figure 4:

	7-00	7-01	7-02	7-03	7-05		7-00	7-01	7-02	7-03	7-05
E	100	20%	1	0	100%	F	100	50%		1	100%

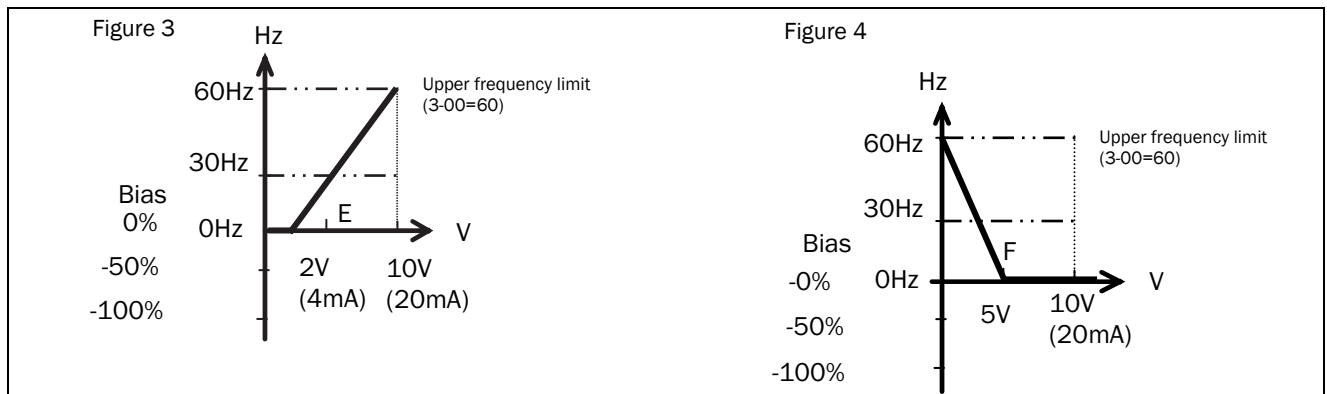

4. The VSD reads the average value of A/D signals once per (7-04×4 ms). Users can determine scan intervals according to noise in the environment. Increase 7-04 in noisy environment, but the response time will increase accordingly.

3.4.8 Parameter Group 8 - Multifunction output terminal and output signal operation mode

Multifunction analogue output control:
 8-00: Analogue Output Voltage Mode:
 0000: Output frequency
 0001: Frequency Setting
 0002: Output voltage
 0003: DC Bus Voltage
 0004: Motor current
 0005: Feedback Signal of PID
 8-01: Analogue Output Gain=0 to 200%

type is determined by the setting 8-01. The function of 8-01 is: when there is tolerance for the external voltage meter and peripheral equipment, please regulate 8-00.

The feedback value of PID (i.e. the input voltage and current of S6) outputs analogue value from the FM+ terminal. (Decides parameter 4-06). The value corresponds to the input signal 0–10V (0–20 mA) or 2–10V (4–20mA).

Note: The max output voltage is 10V due to the circuit, even when the output voltage should be higher than 10 V.

The multifunction analogue output terminal of the terminal block (TM2) is 0–10 VDC analogue output. The output

8-02/03=01:

The preset frequency is reached ($\pm 8-05$)

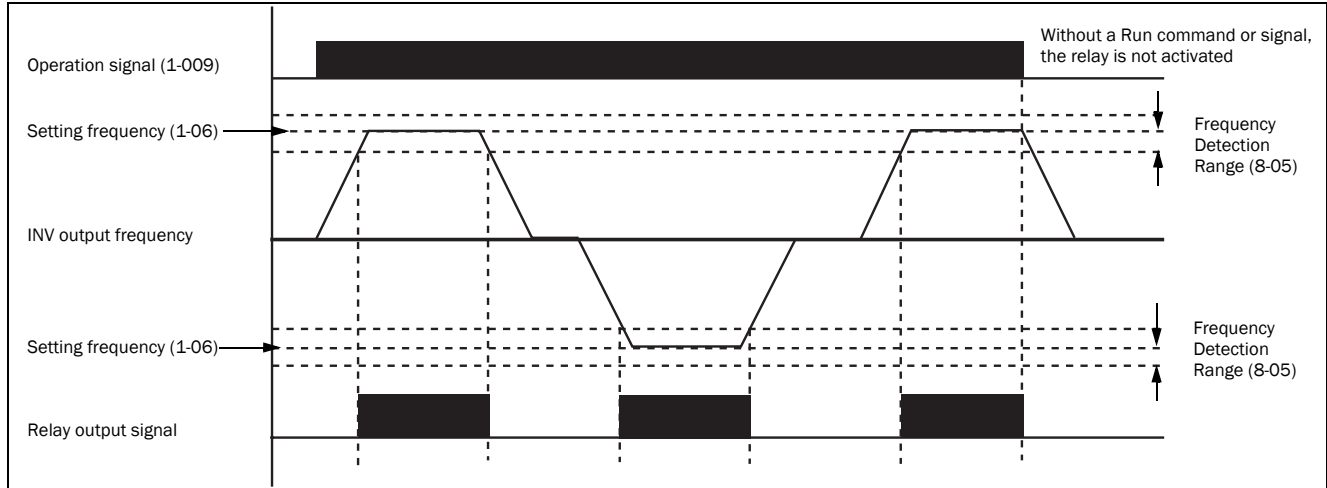

8-02/3=02:

Arbitrary frequency consistency $F_{OUT}=8-04 \pm 8-05$

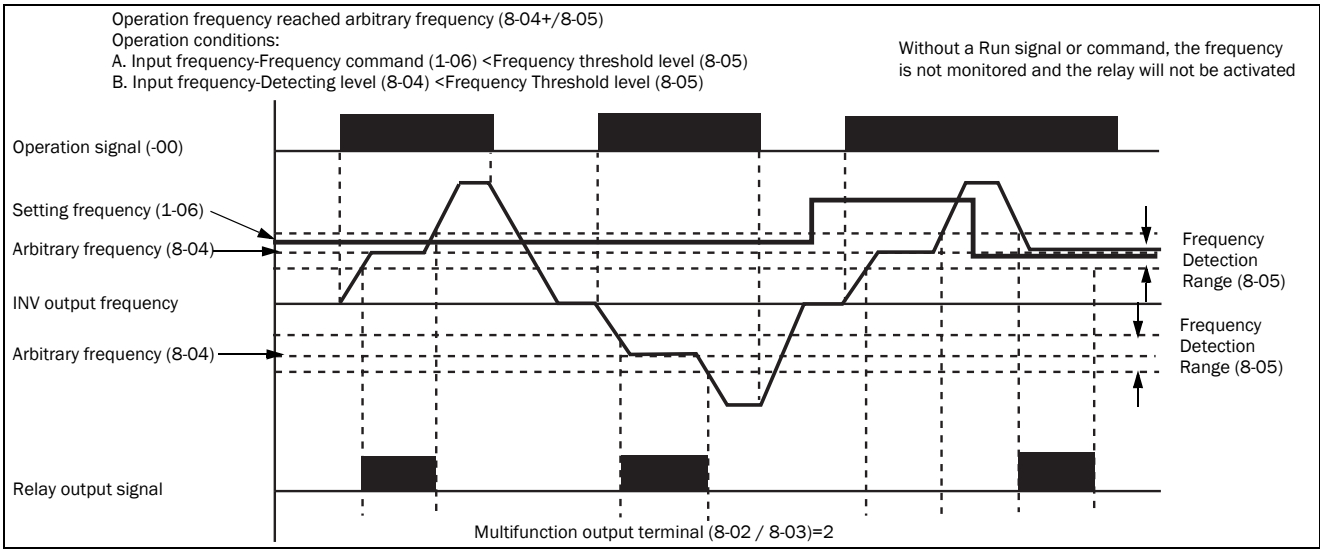

8-02/3=03:

Frequency detection $F_{OUT} > 8-04$

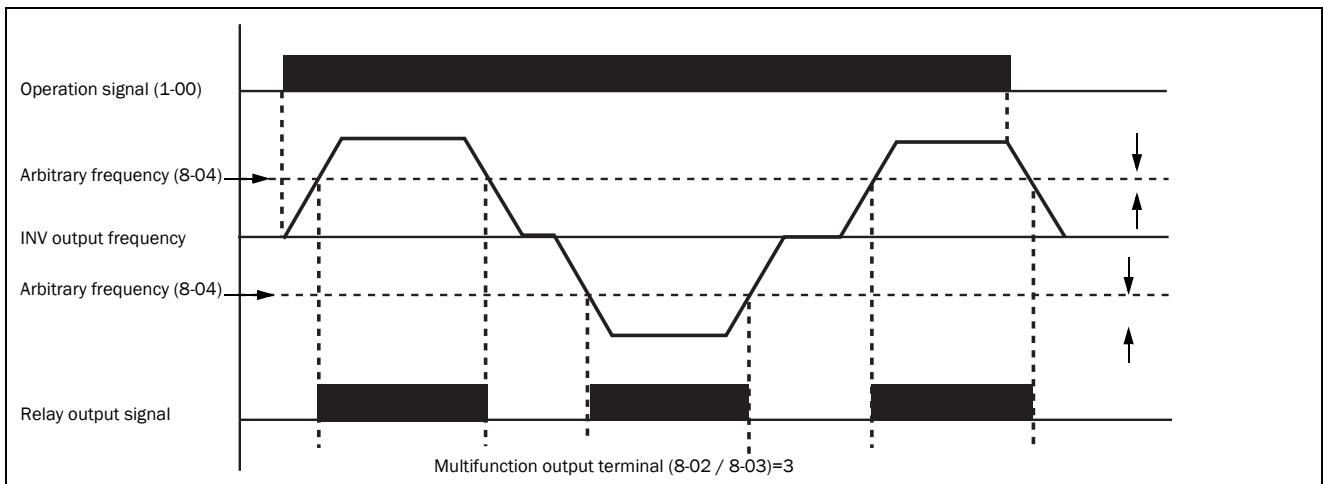

8-02/3=04:

Frequency detection $F_{OUT} < 8-04$

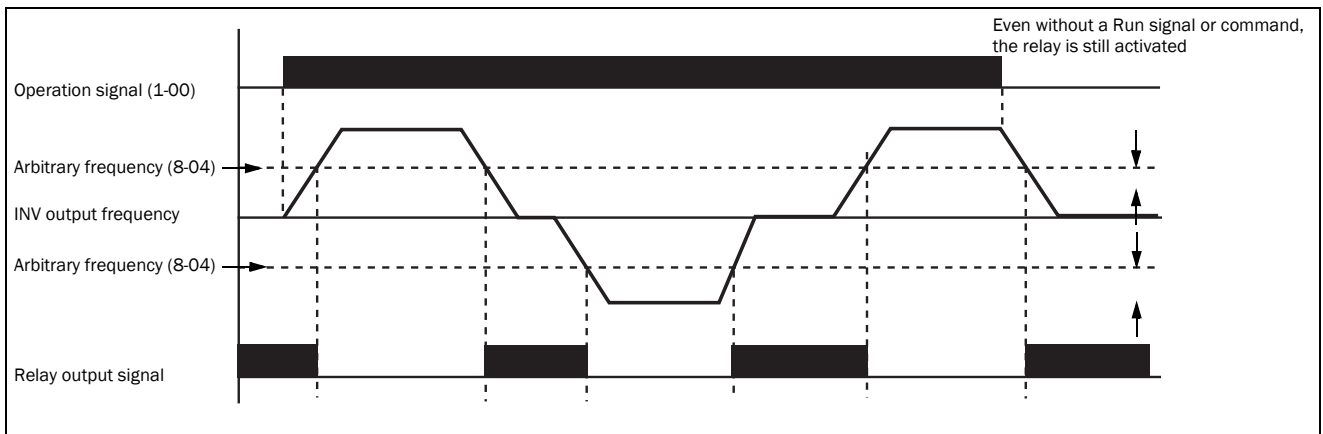

8-02/3=05:

Over torque detection

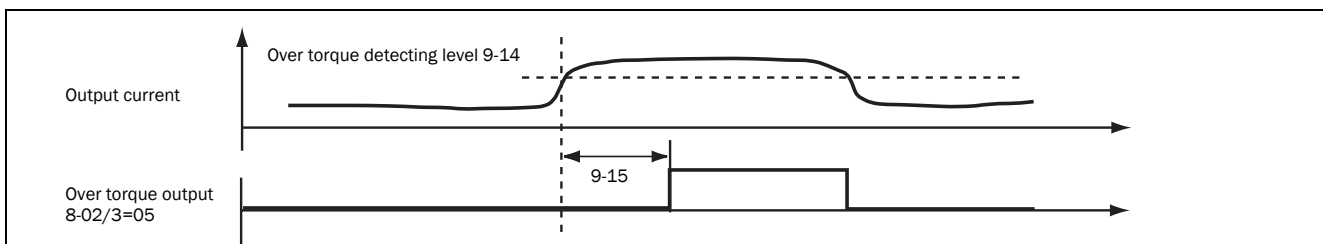

3.4.9 Parameter Group 9 – Drive and Load Protection Modes

9-00: Trip Prevention Selection During Acceleration:
 0000: Enable Trip Prevention During Acceleration
 0001: Disable Trip Prevention During Acceleration

9-01: Trip Prevention Level During Acceleration: 50% to 300%

9-02: Trip Prevention Selection During Deceleration:
 0000: Enable Trip Prevention During Deceleration
 0001: Disable Trip Prevention During Deceleration

9-03: Trip Prevention Level During Deceleration: 50% to 300%

9-04: Trip Prevention Selection in Run Mode:
 0000: Enable Trip Prevention in Run Mode
 0001: Disable Trip Prevention in Run Mode

9-05: Trip Prevention Level in Run Mode: 50% to 300%

9-06: Trip Prevention Deceleration Time Selection in Run Mode:
 0000: Trip Prevention Deceleration Time Set with 3-03
 0001: Trip Prevention Deceleration Time Set with 9-07

9-07: Deceleration Time in Trip Prevention Mode (s): 0.1 to 3600.0

1. When accelerating, the VSD will delay the acceleration time if it is too short and this results in the over current in order to prevent the VSD tripping.
2. When decelerating, the VSD will delay the acceleration time if it is too short and this results in the over voltage of DC VUS in order to prevent the VSD tripping with 'OV' displayed.
3. Some mechanical characteristics (such as pressure) or unusual breakdown (seizure due to insufficient lubrication, uneven operation, impurities in processed materials, etc.) will cause the VSD to trip, thus inconveniencing users. When the operating torque of the VSD exceeds the setting of 9-05, the VSD will lower the output frequency following the deceleration time set by 9-06, and return to the normal operation frequency after the torque stabilises.
4. When the VSD needs to stop immediately and the braking resistor is connected, set 9-02 to 1 to obtain greater braking capacity.

9-08: Electronic Motor Overload Protection Operation Mode:
 0000: Enable Electronic Motor Overload Protection
 0001: Disable Electronic Motor Overload Protection

9-09: Motor Type Selection:
 0000: Electronic Motor Overload Protection Set for Non-VSD Duty Motor
 0001: Electronic Motor Overload Protection Set for VSD Duty Motor

9-10: Motor Overload Protection Curve Selection:
 0000: Constant Torque (OL=103%) (150%,1 minute)
 0001: Variable Torque (OL=113%) (123%,1 minute)

9-11: Operation After Overload Protection is Activated:
 0000: Coast-to-Stop After Overload Protection is Activated
 0001: Drive Will not Trip when Overload Protection is Activated (OL1)

Description of the thermal relay function:

1. 9-10=0000: protect the general mechanical load. If the load is less than 103% rated current, the motor continues to run. If the load is larger than 150% rated current, the motor will run for 1 minute. (Refer to following curve (1).
 = 0001: protects HVAC load (FAN, PUMP, etc.): If the load is less than 113% rated current, the motor continues to run. If the load is larger than 123% rated current, the motor will run for 1 minute.
2. The heat sinking function will decline when the motor runs at low speed. So the thermal relay action level will decline at the same time. (Curve 1 will change to curve 2).
3. 9-09=0000: sets 0-05 as the rated frequency for the slave motor.
 9-11=0000: the VSD coast to stop as the thermal relay acts and flashes OL1. Press 'reset' or the external reset terminal to continue running
 = 0001: the VSD continues to run as the thermal relay acts and flashes OL1. Until the current declines to 103% or 113%(determined by 9-10), OL1 will disappear.

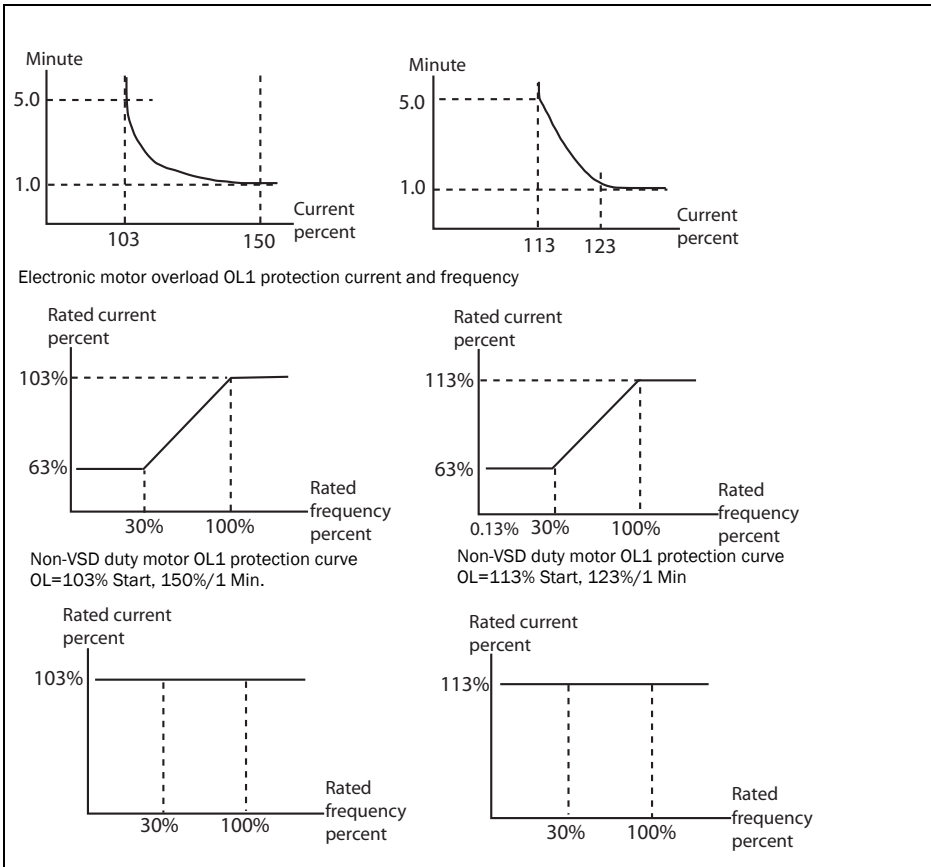

If parameter 8-02,03 (Multifunction output terminal) = 05, the output terminal is output over torque signal.

9-12: Over Torque Detection Selection:

- = 0000: Disable Over Torque Operation
- = 0001: Enable Over Torque Operation Only if at Set Frequency
- = 0002: Enable Over Torque Operation while the Drive is in Run Mode

9-13: Operation After Over Torque Detection is Activated:

- = 0000: Drive will Continue to Operate After Over Torque is Activated
- = 0001: Coast-to-Stop After Over Torque is Activated

9-14: Over Torque Threshold Level (%): 30-200%

9-15: Over Torque Activation Delay Time (s): 0.0-25.0

The over torque is defined as: the output torque is inside parameter 9-15, the voltage level (the VSD rated torque is 100%) is over 9-14 parameter.

9-13=0000: If there is over torque, the VSD can continue to run and flashes OL3 till the output torque is less than the 9-14 setting value.

= 0001: If there is over torque, the VSD coasts to stop and flashes OL3. it is necessary to press 'RESET' or external terminal to continue to run.

NOTE: Over torque output signal will be output when the parameter 9-12=0001 or 0002 when the level and time are above the range.

3.4.10 Parameter Group 10 – Volts / Hz Pattern Operation Mode

V/F pattern Selection

10-0: V/F pattern Selection = 0 to 18

10-1: Torque boost gain (V/F pattern modulation)% = 0.0 to 30.0%

10-2: Motor no load current (Amps AC) -----

10-3: Motor rated slip compensation (%) = 0.0 to 100.0%

10-4: Max output frequency (Hz) = 0.20 to 650.0 Hz

10-5: Max output frequency voltage ratio (%) = 0.0 to 100.0%

10-6: Medium frequency (Hz) = 0.10 to 650.0 Hz

10-7: Medium output frequency voltage ratio (%) = 0.0 to 100.0%

10-8: Min output frequency (Hz) = 0.10 to 650.0 Hz

10-9: Min output frequency voltage ratio (%) = 0.0 to 100.0%

1. 10-0=18, sets the V/F pattern freely complying with 10-4 to 10-9 (Refer to following diagram)

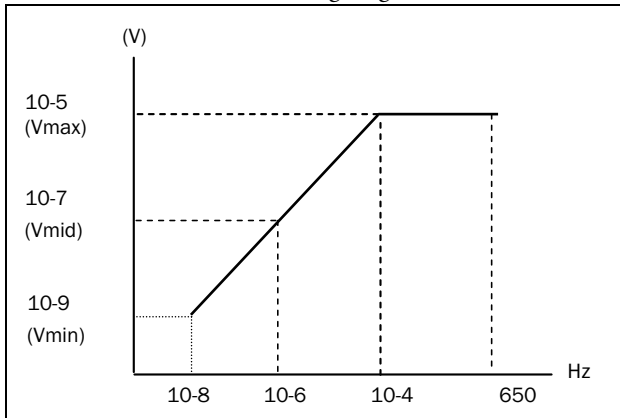

2. 10-0=0 to 17 V/F pattern (Refer to following list) C

Type	Function	10-0	V/F pattern	Type	Function	10-0	V/F pattern
50 Hz	General use	0		60 Hz	General use	9	
	High start torque	1			High start torque	10	
		2				11	
		3				12	
	Decreasing torque	4			Decreasing torque	13	
		5				14	
	Constant torque	6			Constant torque	15	
		7				16	
		8				17	

10-0	B	C
0 / 9	50.0%	1.0%
1 / 10	60.0%	1.0%
2 / 11	65.0%	1.0%
3 / 12	70.0%	1.0%
4 / 13	40.0%	1.0%
5 / 14	35.0%	1.0%
6 / 15	45.0%	1.0%
7 / 16	55.0%	1.0%
8 / 17	65.0%	1.0%

3. The VSD will output the value in B, C and voltage (refer to 10-0) plus 10-1 V/F pattern setting. The start torque will also be raised.

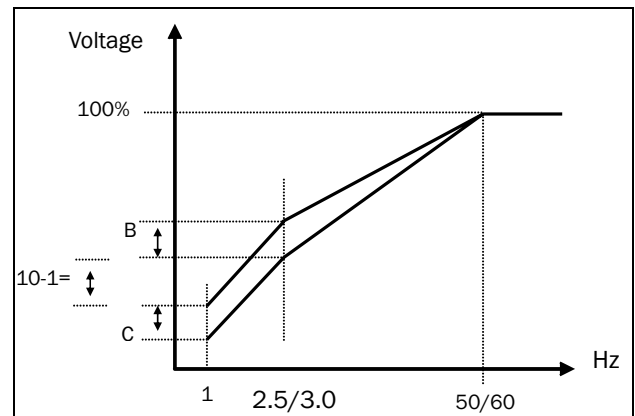

4. When the induction motor is running, there must be slip due to the load. Boost is necessary to improve the precision of the speed.

$$\text{Slip frequency boost} = \frac{\text{Output Current}-(10-2)}{(0-02)-(10-2)} \times (10-3)$$

Note: 0-02 = motor rated current 10-2 = motor no load current

$$10-3 \text{ rough value} = (\text{Motor synchronization speed} - \text{Rated speed}) / \text{Motor synchronization speed}$$

Marked on the motor nameplate

$$\text{Motor synchronization speed (RPM)} = \frac{120}{\text{Motor Poles}} \times \text{Motor rated frequency (50Hz or 60Hz)}$$

$$\text{e.g.: 4-pole 60 Hz induction motor synchronization speed} = \frac{120}{4} \times 60 = 1800 \text{ RPM}$$

Note: Motor with no load current (10-2) differs from the VSD capacities in 15-0 (refer to 0-02 note). It should be regulated according to the actual condition.

3.4.11 Parameter group 11 - PID operation mode

11-0: PID Operation Selection

0000: PID disable
0001: PID enable (deviation is D-controlled)
0002: PID feedback D-controlled
0003: PID D reverse characteristic controlled
0004: PID feedback D characteristic controlled
0005: PID frequency command + D controlled
0006: PID frequency command + feedback D controlled
0007: PID frequency command + D reverse characteristic controlled.
0008: PID frequency command + feedback D reverse characteristic controlled.

11-0 =1, D is the deviation of (target value – detected value) in the unit time (11-4).

=2, D is the deviation of the detected values in unit time (11-4).

=3, D is the deviation of (target value – detected value) in the unit time (11-4). If the deviation is positive, the output frequency decreases, and vice versa.

=4, D is the deviation of detected value in unit time (11-4). When the deviation is positive, the frequency decreases, and vice versa.

=5, D is equal to the deviation of (target value – detected value) in unit time (11-4) + Frequency command.

=6, D is equal to the deviation of detected values in unit time + Frequency command.

=7, D is equal to the deviation of (target value – detected value) in unit time + Frequency command. If the deviation is positive, the output frequency decreases, and vice versa.

=8, D is equal to the deviation of detected values in unit time + Frequency command. When the deviation is positive, the frequency decreases, and vice versa.

11-1: Feedback Calibration Gain (%): 0.00 to 10.00

11-1 is the calibration gain. Deviation = (target value – detected value) × 11-1.

11-2: Proportion Gain (%): 0.00 to 10.00

11-2: Proportion gain for P control.

11-3: Integrate Time (s): 0.0 to 100.0

11-3: Integrate time for I control.

11-4: Differential Time (s): 0.00 to 10.00

11-4: Differential time for D control.

11-5: PID Offset: 0000: Positive Direction

0001: Negative Direction

11-6: PID Offset Adjust (%): -109% to +109%

11-5/11-6: PID the calculated result pluses 11-6 (the sign of 11-6 is determined by 11-5).

11-7: Output Lag Filter Time (s): 0.0 to 2.5

11-7: Updates time for output frequency.

NOTE: PID Function is available for controlling the output flow, external fan flow and temperature. The controlling flow is as follows:

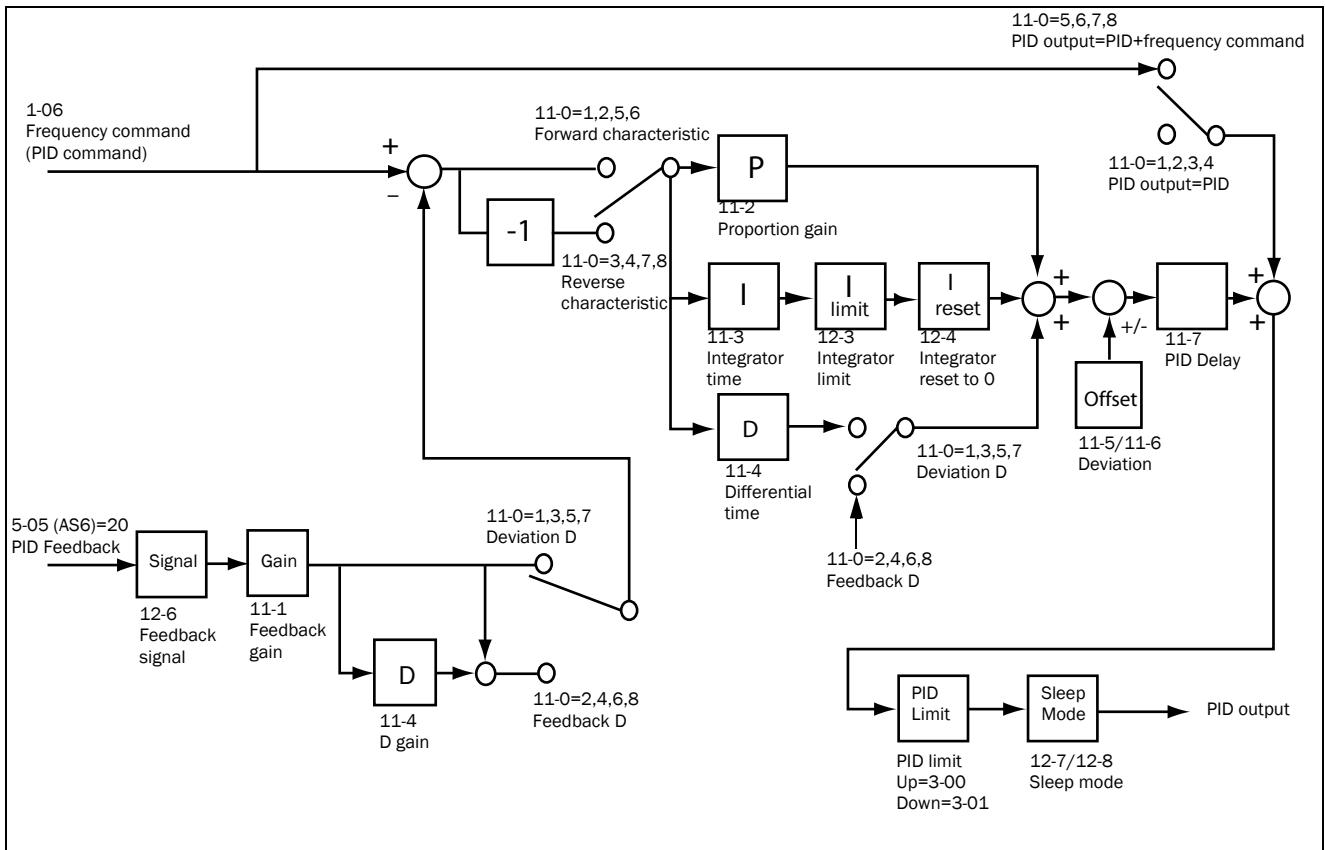

1. For performing PID control, set 5-05=20, AI2 (S6) on TM2 as PID feedback signal.
2. The target value of above diagram is the 1-06 input frequency.
3. There are two ways to see the PID feedback signal, one is using the keypad switch display (4-06 must be set as 1); the other is using analogue output FM+ (8-00 must be set as 5).

3.4.12 Parameter Group 12 - PID "Limits" and "Out of Range" Mode

12-0: Feedback Loss Detection Mode:
 0000: Disable
 0001: Enable – Drive Continues to Operate After Feedback Loss
 0002: Enable – Drive “STOPS” After Feedback Loss

12-0=0: Disable; 12-0=1: detection for running and display PDER
 12-0=2: detection for stopping and display PDER.

12-1: Feedback Loss Detection Mode (%): 0 to 100

12-1 is the level for signal loss. Deviation = Command value – Feedback value. While the deviation is larger than the loss level, the feedback signal is lost.

12-2: Feedback Loss Detection Delay Time (s): 0.0 to 25.5

12-2: The action delay time if the feedback signal is lost.

12-3: Integrate Limit Value (%): 0 to 109

12-3: The Limiter prevents PID saturation.

12-4: Integrator Reset to 0 when Feedback Signal Equals the Intended Value:
 0000: Disable
 0001: 1 second
 0030: 30 seconds

12-4=0: When PID feedback value reaches the command value, the integrator will not be reset to 0.

12-4=1 to 30: When PID feedback value reaches the target value, it resets to 0 in 1 to 30 seconds and the VSD stops output. The VSD will start output again if the feedback value differs from the target value.

12-5: Allowable Integration Error Margin (Unit Value) (1 Unit = 1/8192): 0 to 100

12-5=0 to 100% unit value: restart the tolerance after the integrator is reset to 0.

12-6: PID Feedback Signal: 0000: 0–10V or 0–20 mA
0001: 2–10 V or 4–20 mA

12-6: Feedback signal selection, 12-6=0: 0–10 V or 0–20 mA (signal V or I set by SW2)

12-6=1: 2–10 V or 4–20 mA (signal V or I set by SW2).

12-7, 12-8: PID Sleep Mode

PID Sleep Mode:

11-0=1 (PID Enable)

5-05=20 (PID Feedback Enable)

1-06 = PID setting frequency source (Target Value)

12-7 Sets the frequency for sleep start, Unit: Hz

12-8 Sets the Time for sleep delay, Unit: sec

When PID output frequency is less than the frequency for sleep start and it reaches the time of sleep delay, the VSD will decelerate to 0 and enter PID sleep mode.

When PID output frequency is larger than the frequency for sleep start the VSD will be woken and enter PID awake mode. The time diagram is as follows:

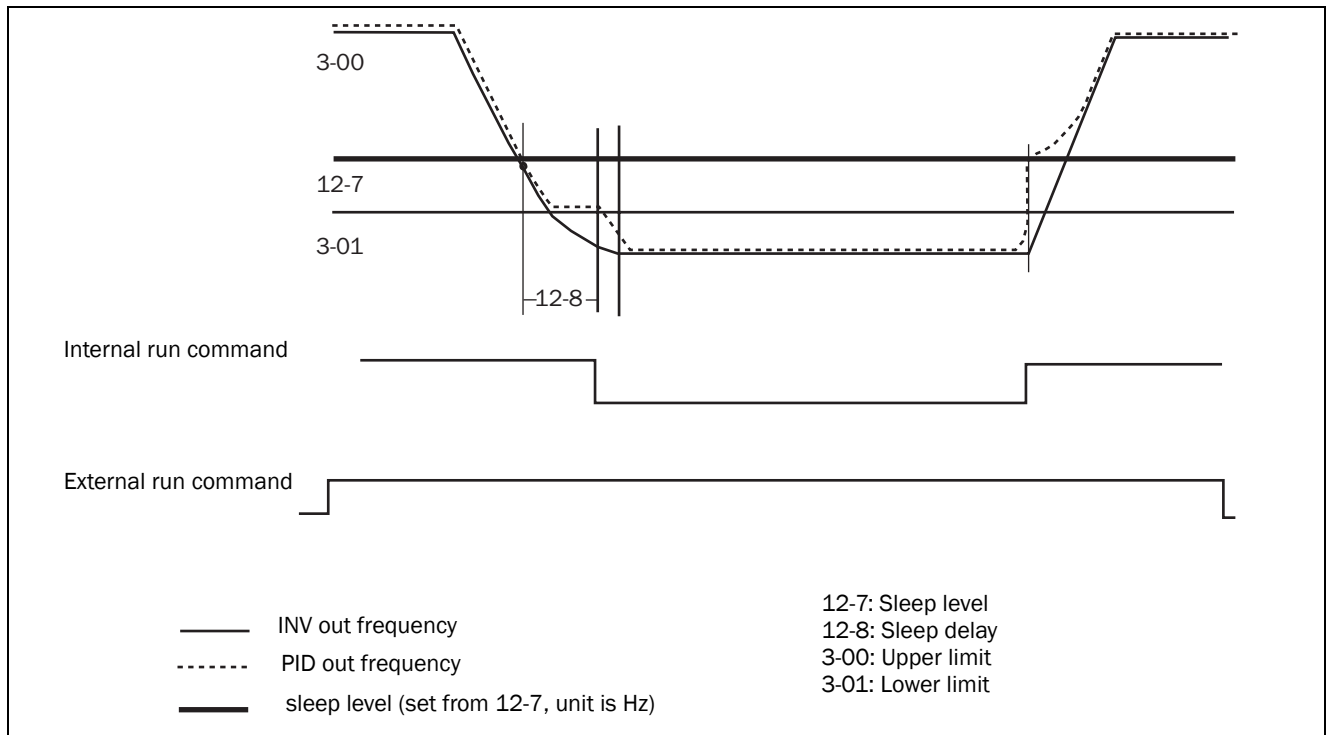

3.4.13 Parameter Group 13 - Communication mode

13-0: Assigned Communication Station Number: 1 - 254

13-0: Sets the communication station codes which are suitable for driving the situations of more than one VSD.

13-1: Baud Rate setting (bps): 0000: 4800
 0001: 9600
 0002: 19200
 0003: 38400
 13-2: Stop Bit Selection:
 0000: 1 stop bit
 0001: 2 stop bit
 13-3: Parity Selection: 0000: no parity
 0001: even parity
 0002: odd parity
 13-4: Data Format Selection: 0000: 8 bit data
 0001: 7 bit data

- RS-485 Communication:
 - 1 vs. 1 Control: controlling one VSD with a PC, PLC or controller. (Set 13-0=1 to 254)
 - 1 vs. more Control: controlling more than one VSD with PC, PLC or controller. (The max. number of VSDs is 254. Set 13-0=1 to 254). When the VSD receives the communication station code = 0, the communication control is acceptable regardless of the set value for 13-0.
- RS-232 communication: (RS232 interface is required) 1 vs. 1 control: controlling one VSD with a PC, PLC or controller. (Set 13-0=1 to 254).

NOTE: a. The BAUD RATE (13-1) of the PC (or PLC or controller) and of the VSD should be set to the same level. Communication format (13-2/13-3/13-4) should be set to the same one.

b. The VSD will confirm the parameter co-efficient when the PC modifies the parameter of the VSD.

c. Please refer to the VSC Communication PROTOCOL.

3.4.14 Parameter Group 14 - Autotuning

14-0: Stator Resistance (Ohms) Gain
 14-1: Rotator Resistance (Ohms) Gain
 14-2: Equivalent Inductance (mH) Gain
 14-3: Magnetized Current (Amps AC) Gain
 14-4: Ferrite Loss Conduction (gm) Gain

- If 0-00=0 or 1 (vector mode) is selected, when power ON, set 0-06=1, the motor will run as the VSD performs autotuning. When the motor stops, it means that autotuning is finished. The VSD will write the internal parameter of the motor to 14-0 to 14-4, and auto reset the 0-06 back to 0.
- Autotuning must be carried out if the motor has been changed. If the internal parameters are known already, they can be entered to 14-0 to 14-4 directly.
- 0-06=1 to perform autotuning. When finished, 0-06 is auto reset to 0, the Keypad displays END.
- The parameter group only affects the current vector.



3.4.15 Parameter Group 15 - Operation Status and Function Reset

15-0: Drive Horsepower Code

15-0	VSD Model	
405	VSC48	009
408		013
410		018

15-1: Software Version

15-2: Fault JogLatest 3 times

- When the VSD doesn't work normally, the previous fault log stored in 2.xxxx will be transferred to 3.xxxx and then the one in 1.xxxx to 2.xxxx. The present fault will be stored in the blank 1.xxxx. Thus the fault stored in 3.xxxx is the earliest one of the three, while the one 1.xxxx is the latest.
- Enter 15-2, the fault 1.xxxx will be displayed first, press . Now you can read 2.xxx3.xxx1.xxx, whereas with , the order is 3.xxx2.xxx1.xxx3.xxx.
- Enter 15-2, the three fault log will be cleared once the reset key is pressed. The log content will be changed to 1.---2.---3.---

4. E.g. if the fault log content is '1.OCC', which indicates the latest fault is OC-C, etc.

15-3: Accumulated Operation Time 1 (hours): 0 – 9999
15-4: Accumulated Operation Time 2 (hours X 10000): 0 - 27
15-5: Accumulated Operation Time Mode: 0000: Power on time
0001: Operation time

1. When the operation time goes up to 9999 this set operation duration 1. The next hour will be carried to operation duration 2. Meanwhile, the recorded value will be cleared to 0000, and the recorded value of operation duration 2 will be 01.
2. Description of operation time selection:

Preset value	Description
0	Power on, counts the accumulated time.
1	VSD operation, counts the accumulated operation time

15-6: Reset the factory setting:
1110: Reset the 50Hz factory setting
1111: Reset the 60Hz factory setting
1112: Reset PLC program

If 15-6 is set to 1111, the parameter will be reset to factory setting. The max output voltage will comply with the voltage and frequency (0-01/0-05) on the nameplate of the motor. The output frequency is 60 Hz if the upper frequency limit is not set.

NOTE: In V/F control mode, motor parameters (14-0 to 14-4) will be modified when resetting factory setting.

However, in vector control mode, motor parameters (14-0 to 14-4) will not be modified when resetting factory setting.

3.5 Specification description for built-in PLC function

The VSC has a simple, built-in PLC function. The user can easily download the Ladder Diagram from PC (Windows based software) or PDA (WinCE based software).

3.5.1 Basic instructions

	□	∧	∨	P		⊥	NO / NC
Input instructions					I	i	I1-I7 / i1-i7
Output instructions	Q	Q	Q	Q	Q	q	Q1-Q2 / q1-q2
Auxiliary instructions	M	M	M	M	M	m	M1-MF / m1-mF
Special register							V1-V7
Counter instructions	C				C	c	C1-C4 / c1-c4
Timer instructions	T				T	t	T1-T8 / t1-t8
Analogue comparison instructions	G				G	g	G1-G4 / g1-g4
Encoder comparison instructions	H				H	h	H1-H4 / h1-h4
Operating instructions	F				F	f	F1-F8 / f1-f8

Descriptions for Special Register

V1: Setting Frequency	Range: 0.1-650.0Hz
V2: Operating Frequency	Range: 0.1-650.0Hz
V3: AIN Input value	Range: 0-1000
V4: S6 Input Value	Range: 0-1000
V5: Keypad VR Input Value	Range: 0-1000
V6: Operating Current	Range: 0.1-999.9A
V7: Torque Value	Range: 0.1-200.0%

Connection symbol	Description
—	Connecting left and right components
⊥	Connecting left, right and upper components
⊕	Connecting left, right, upper and lower components
T	Connecting left, right and lower components

	Upper differential	Lower differential	Other Instruction Symbol
Differential instructions	D	d	
SET instructions			∧
RESET instructions			∨
P instructions			P

Open circuit (On status)	"..."	
Closed circuit (Off status)	"- -"	

3.5.2 Function of basic instructions

Function D (d) Command

Sample 1: I1-D- -[Q1

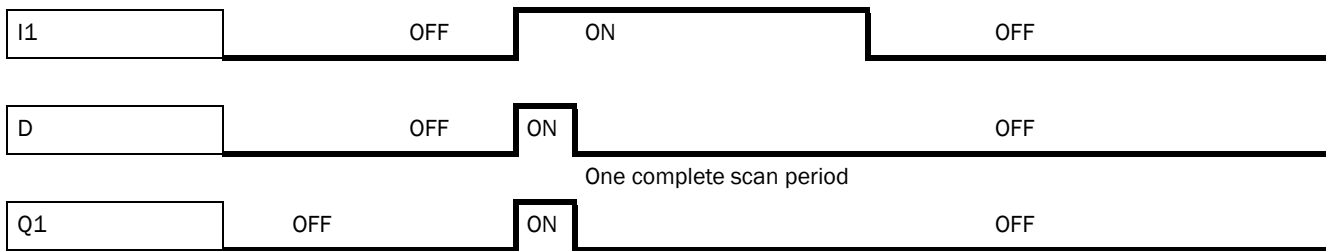

Sample 2: i1- d- -[Q1

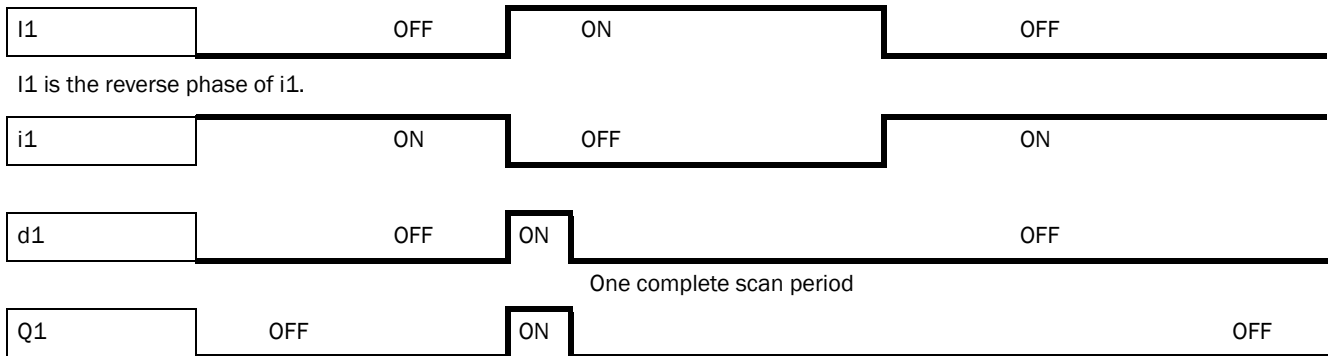

I1 is the reverse phase of i1.

NORMAL (- []) Output

I1-[Q1

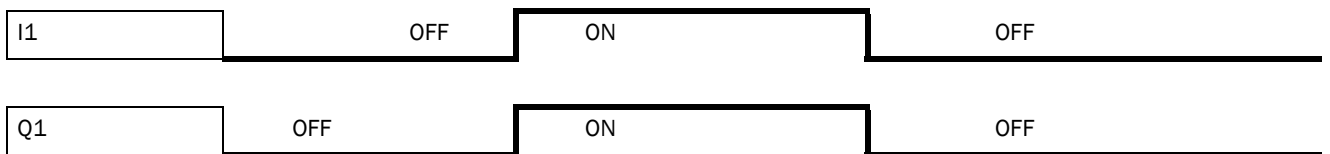

SET (^) Output

I1-^Q1

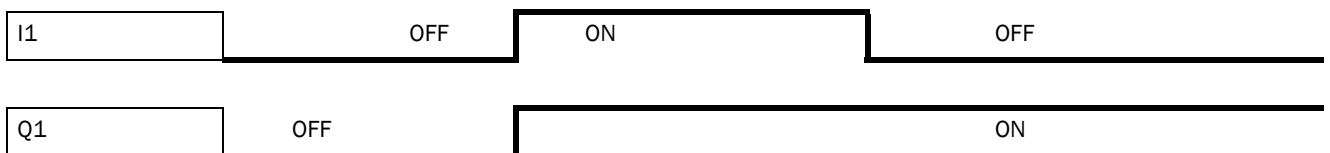

RESET (v) Output

I1-vQ1

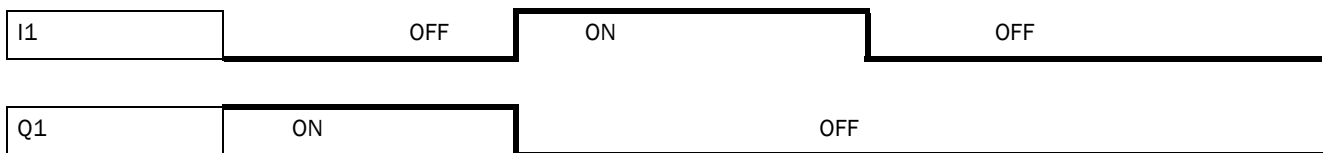

P Output

i1-PQ1

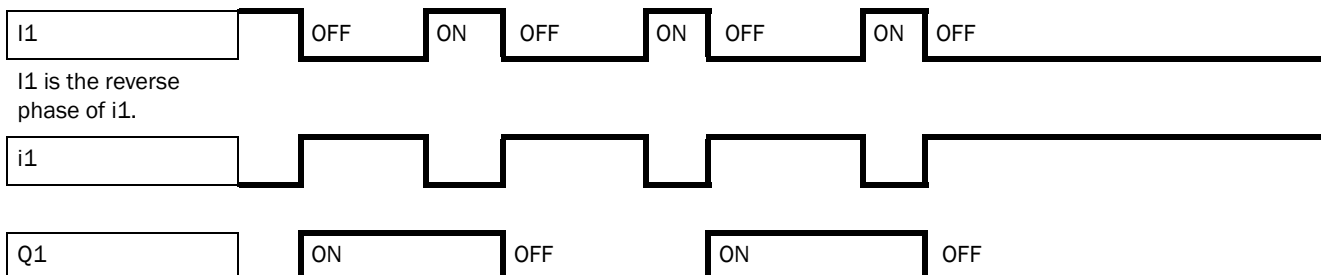

I1 is the reverse phase of i1.

3.5.3 Application instructions

Counter

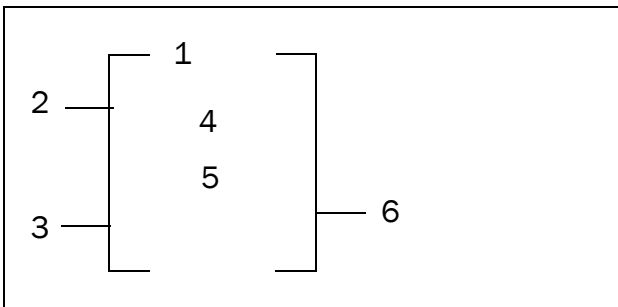

Symbol	Description
1	Counting Mode (1-4)
2	Use (I1 to f8) to set counting up or counting down OFF: counting up (0, 1, 2, 3, 4....) ON: counting down (...3, 2, 1, 0)
3	Use (I1 ~ f8) to RESET the counting value ON: the counter is initialized to zero and (6) OFF OFF: the counter continues to count
4	Preset Counting Value
5	Target (Setting) Value
6	Code of the counter (C1 ~ C4 total: 4 groups).

Counter Mode 1

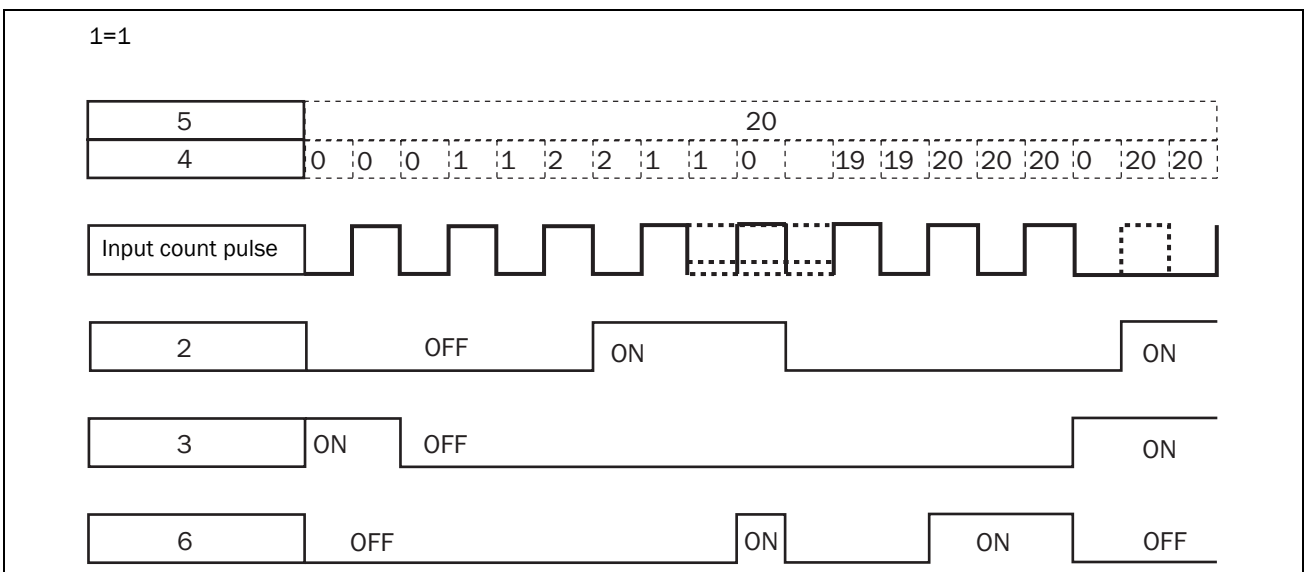

Sample:

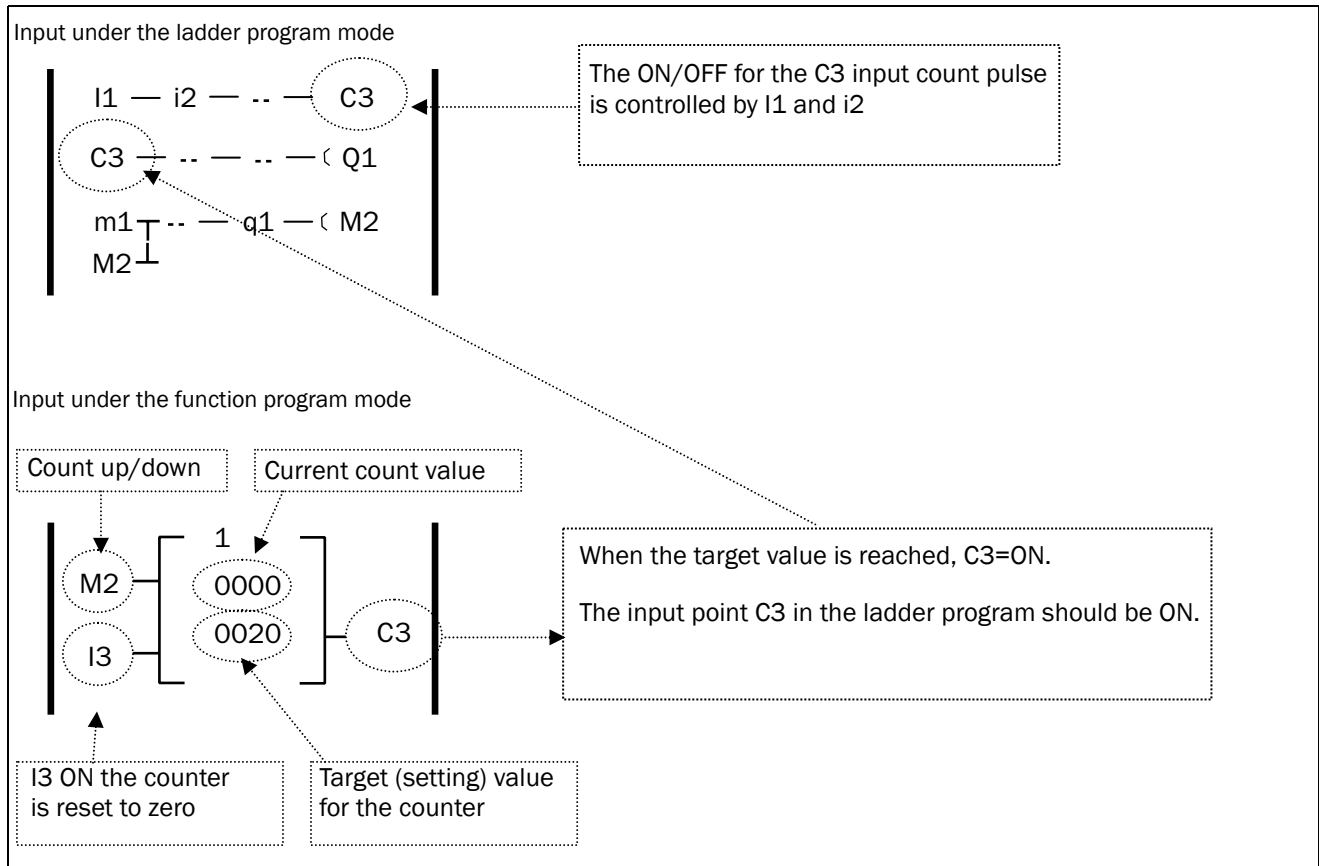

Counter Mode 2

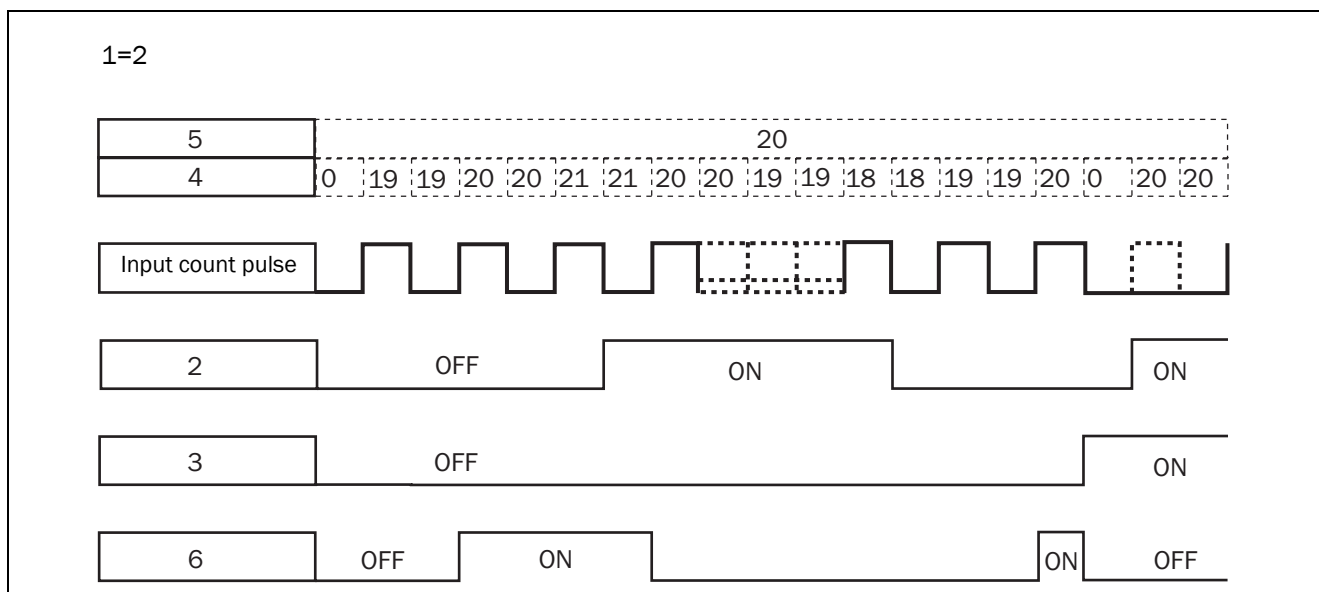

NOTE: In Mode 2, the counting preset value that appears will be greater than 20, unlike in Mode 1, in which the value is locked at 20.

Counter Mode 4 is similar to counter Mode 2 except that the former remembers the recorded value after the power is cut off and continues counting from this point when the power is next turned on.

(3) Counter Mode 3 is similar to counter Mode 1 except that the former remembers the recorded value after the power is cut off and continues counting from this point when the power is next turned on.

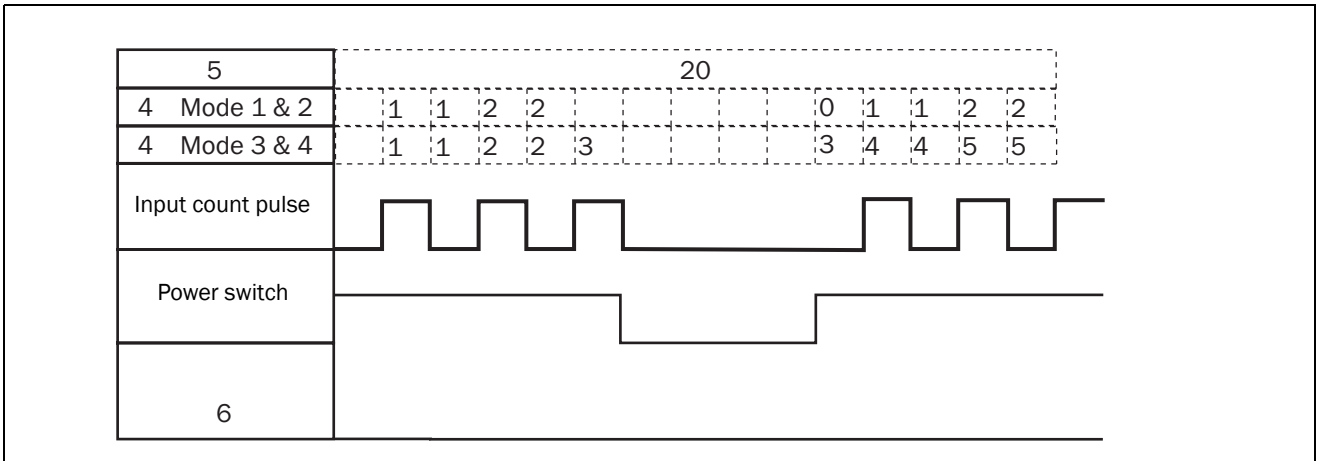

Timer

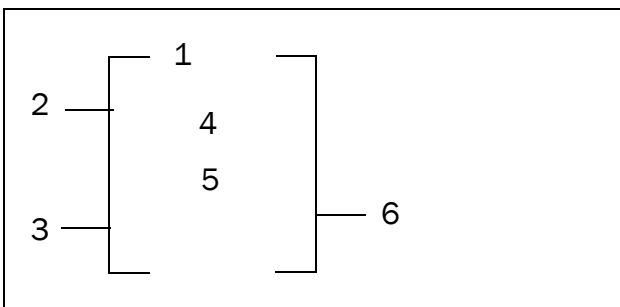

Symbol	Description
1	Timing Mode (1-7)
2	Timing unit 1: 0.0 - 999.9 sec 2: 0 - 9999 sec 3: 0 - 9999 min
3	Use (I1 ~ f8) to RESET the timing value. ON: the counter is reset to zero and (6) OFF OFF: the counter continues to count
4	Preset Timing Value
5	Target (setting) Timing Values
6	The code of the Timer (T1 to T8 total: 8 groups).

Timer Mode 1 (ON-Delay A Mode)

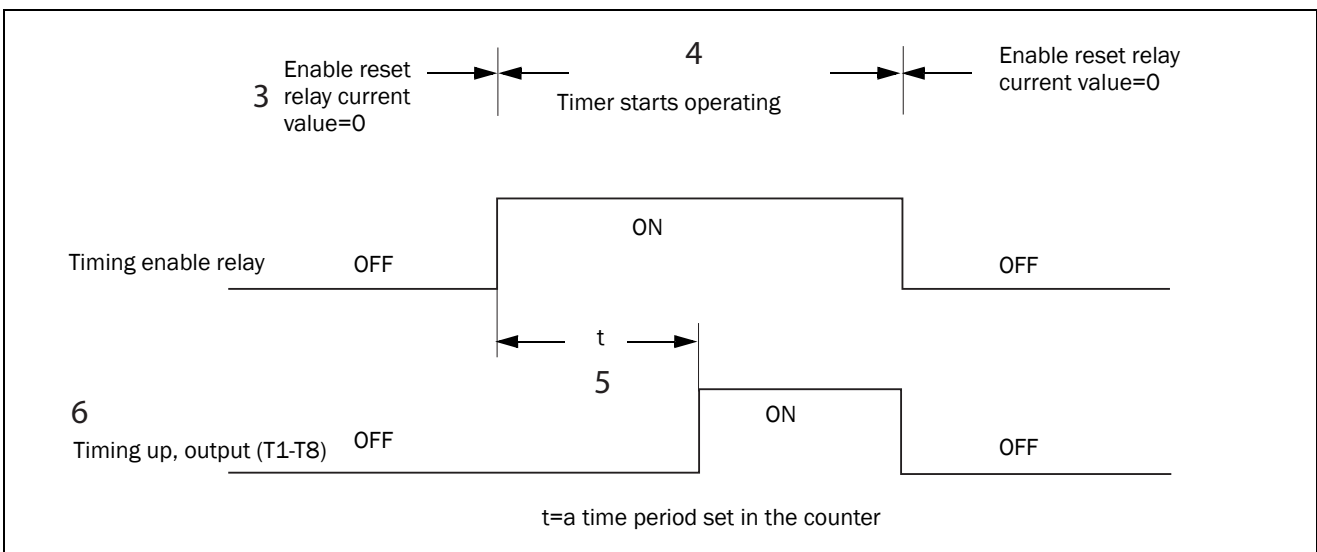

Sample:

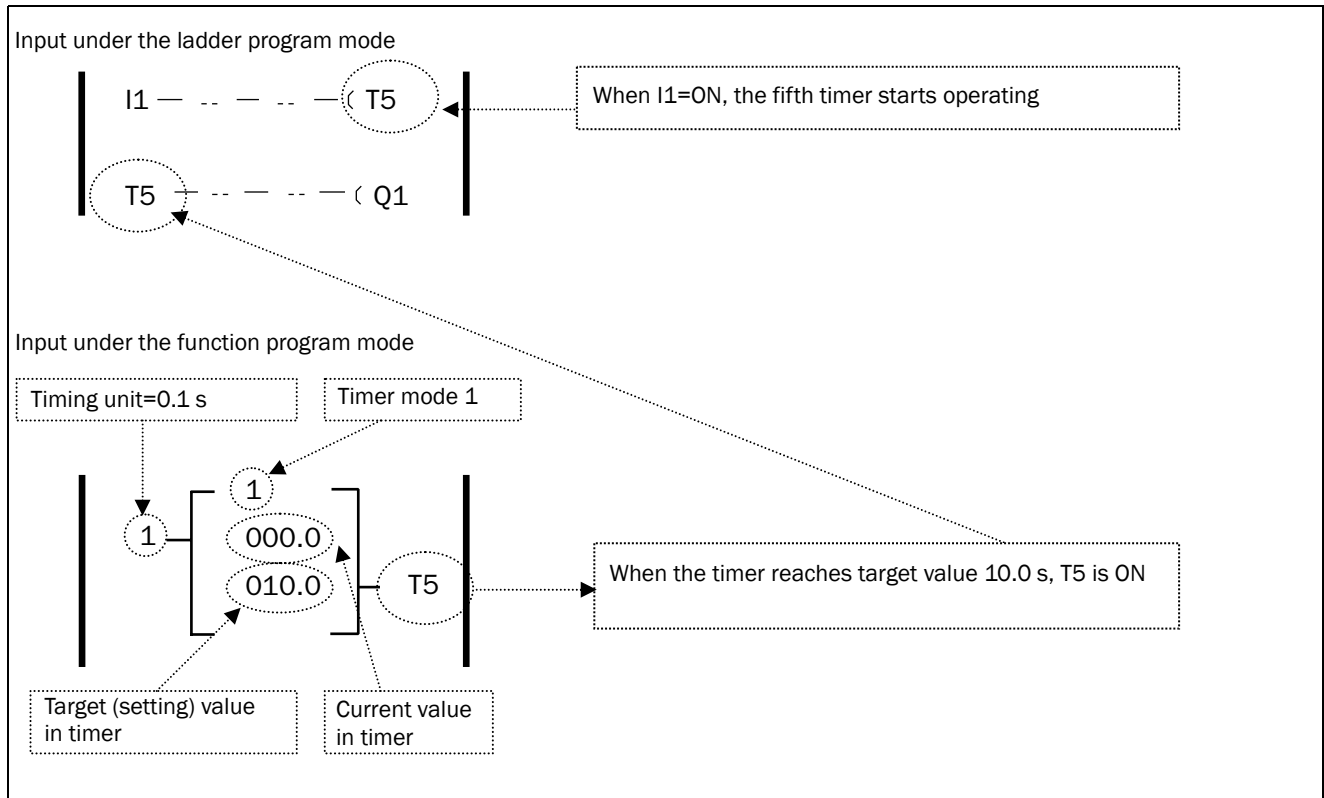

Timer Mode 2 (ON-Delay B Mode)

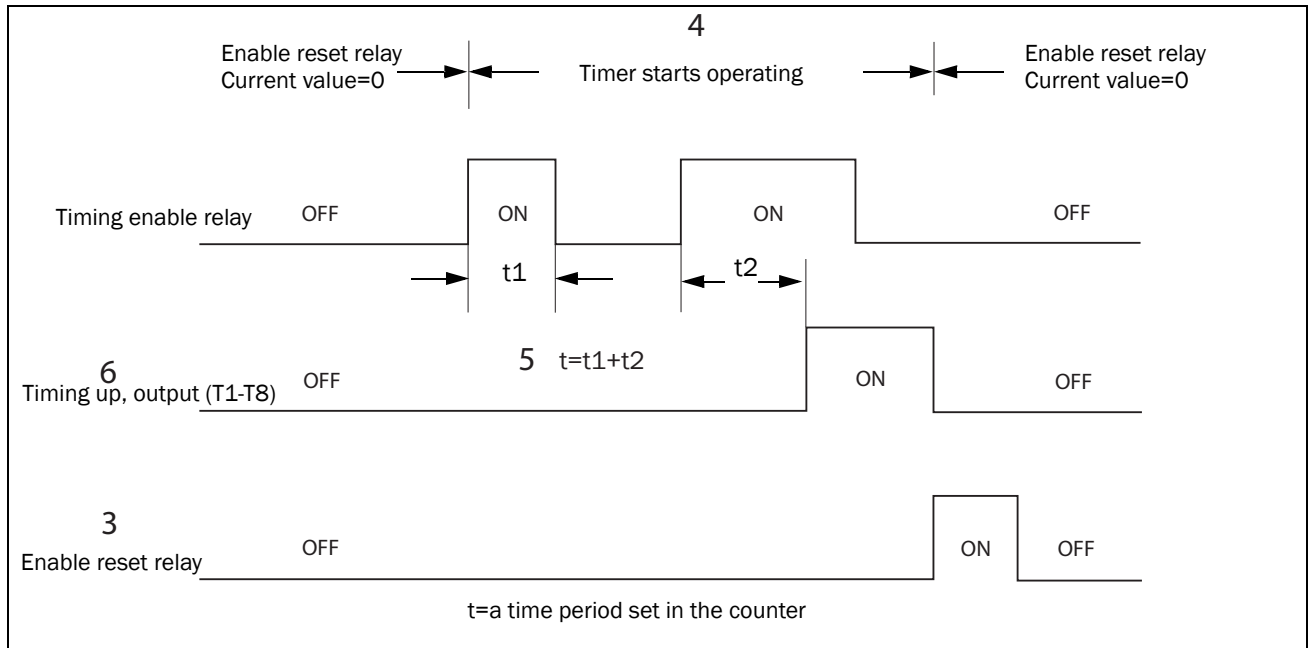

Timer Mode 3 (OFF-Delay A Mode)

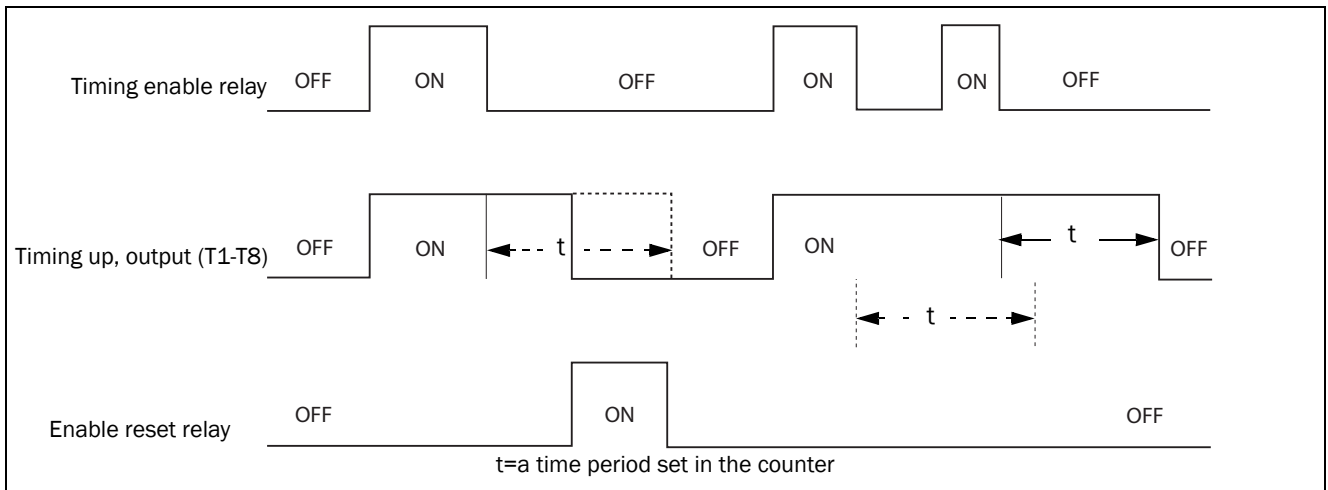
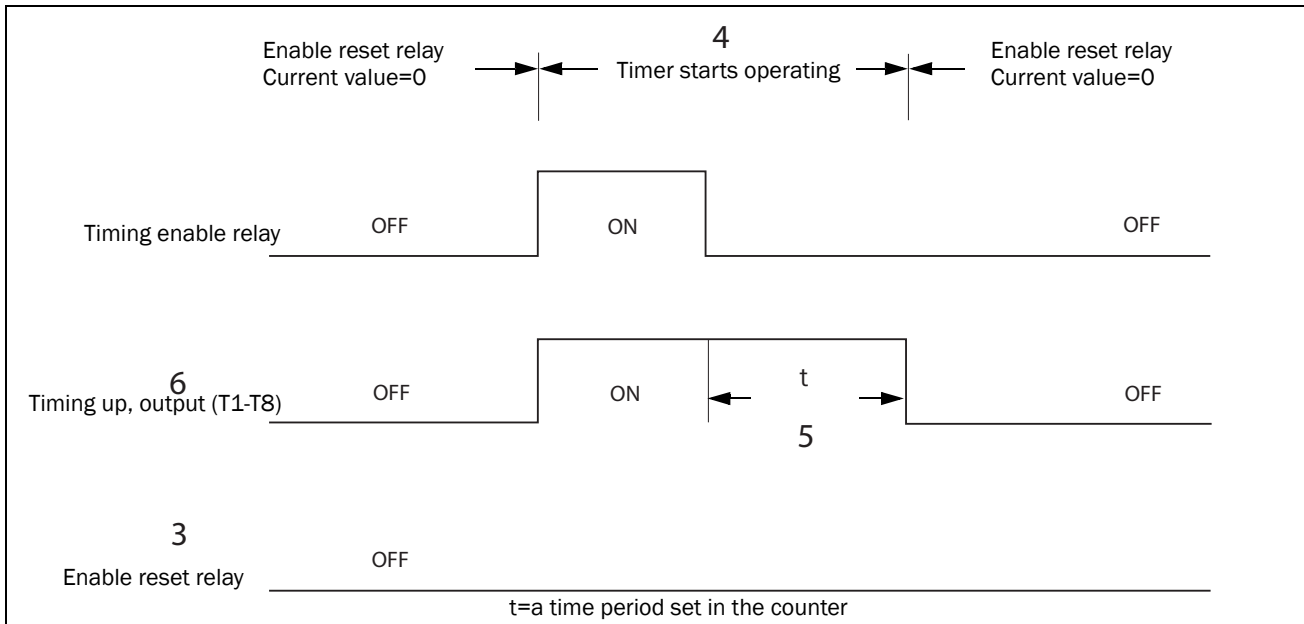

Timer Mode 4 (OFF-Delay B Mode)

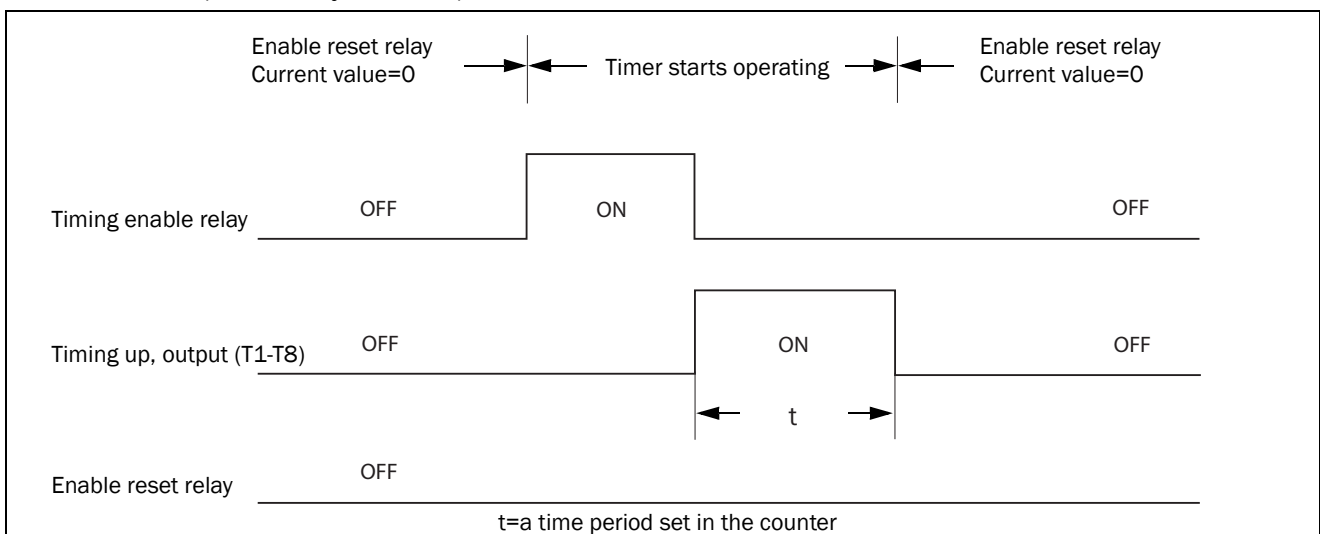

Timer Mode 5 (Flash A Mode)

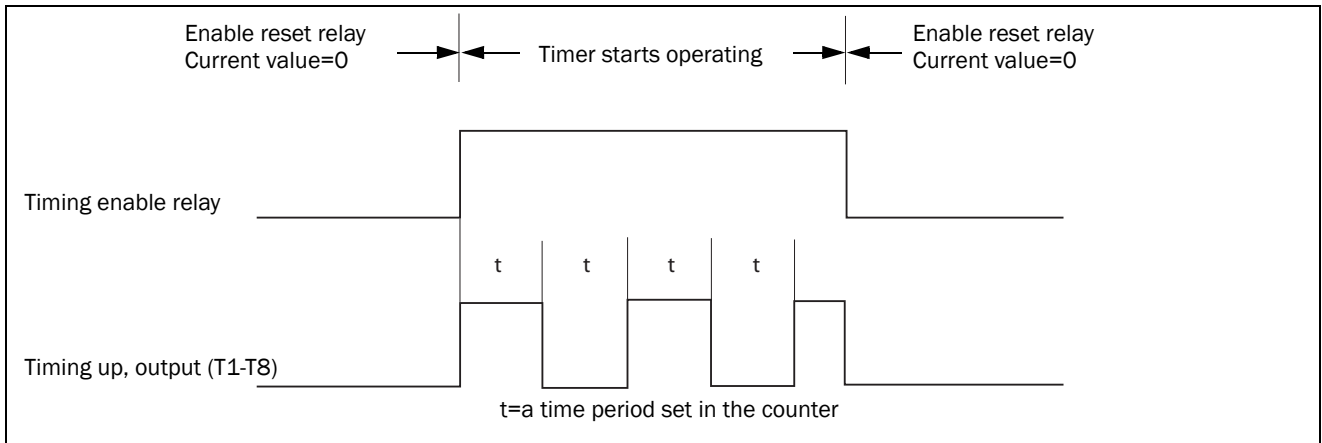

Timer Mode 6 (Flash B Mode)

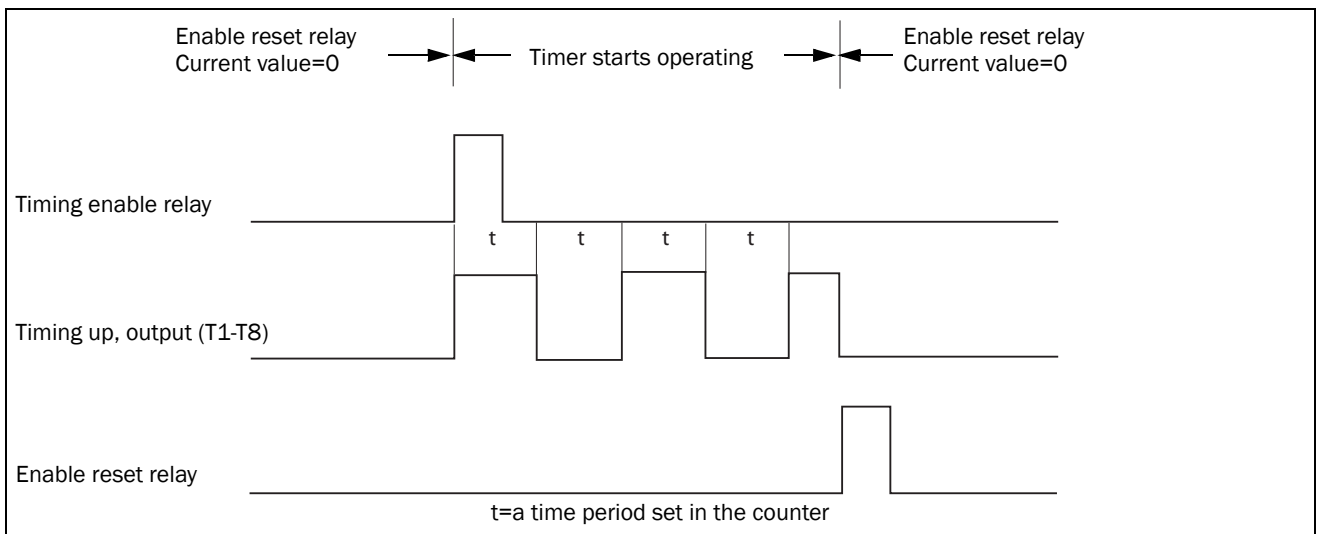

Timer Mode 7 (Flash C Mode)

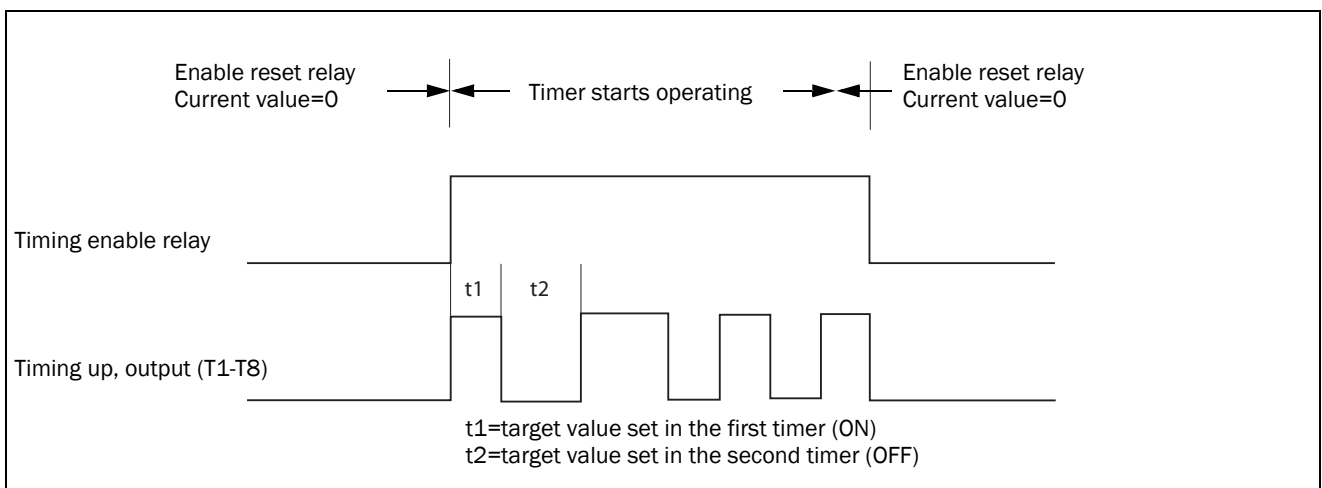

Analogue comparator

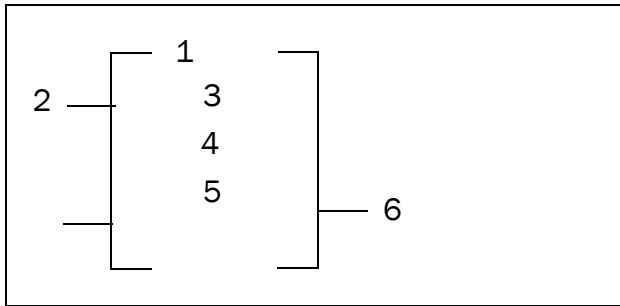

Symbol	Description
1	Analogue comparison mode (1-3)
2	Selection of the input comparison value
3	Analogue input value
4	Setting reference comparison value (upper limit)
5	Setting reference comparison value (lower limit)
6	Output terminals of analogue comparator (G1-G4)

Analogue Comparison Mode (1-3)

- (1) Analogue comparator mode 1 ($3 \leq 5, 6$ ON)
- (2) Analogue comparator mode 2 ($3 \geq 4, 6$ ON)
- (3) Analogue comparator mode 3 ($5 \leq 5 \leq 4, 6$ ON)

Selection of the input comparison value (V1-V7)

- (1) The input comparison value =V1: Setting Frequency
- (2) The input comparison value =V2: Operation Frequency
- (3) The input comparison value =V3: AIN Input Value
- (4) The input comparison value =V4: AI2 Input Value
- (5) The input comparison value =V5: Keypad VR Input Value
- (6) The input comparison value =V6: Operation Current
- (7) The input comparison value =V7: Torque Value

Encoder input Comparison Instruction

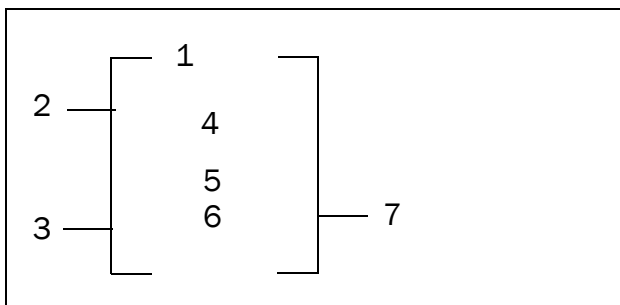

Symbol	Description
1	Encoder control mode (1-2)
2	Use (I1 ~ f8) to set counting up or counting down OFF: counting up (0, 1, 2, 3, 4....) ON: counting down (...3, 2, 1, 0)
3	Use (I1~f8) to Reset counting value.
4	A1, Encoder Input Value/Encoder dividing ratio (6)
5	A2, Setting comparison value
6	C, Encoder dividing ratio
7	Encoder comparison output terminal, H1~H4

Control Mode 1

Encoder Comparison Function: A1/CA2 Comparison Output

Control Mode 2

Encoder Comparing Function: A1/CA2 Comparison Output.

Comparison Enable/Disable of the Encoder input value is determined by the Ladder Program ON/OFF.

Running Instruction

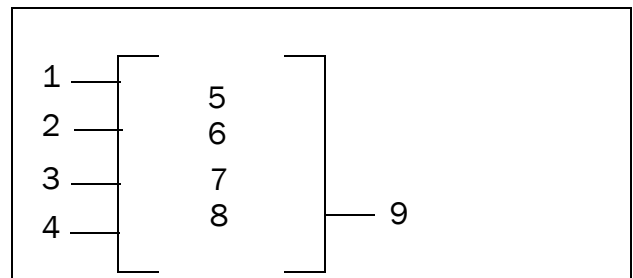

Symbol	Description
1	Running mode can be set via I1~f8 OFF (REV) ON (FWD)
2	Segment Speed can be set via I1~f8 OFF (FWD) ON (REV)
3	Select constant or V3, V5 for Setting Frequency
4	Select constant or V3, V5 for Preset Speed
5	Acceleration Time
6	Deceleration Time
7	Setting Frequency (Could be a constant or V3, V5)
8	Segment Speed (Could be a constant or V3, V5)
9	Instruction code for operation (F1~F8)

Sample:

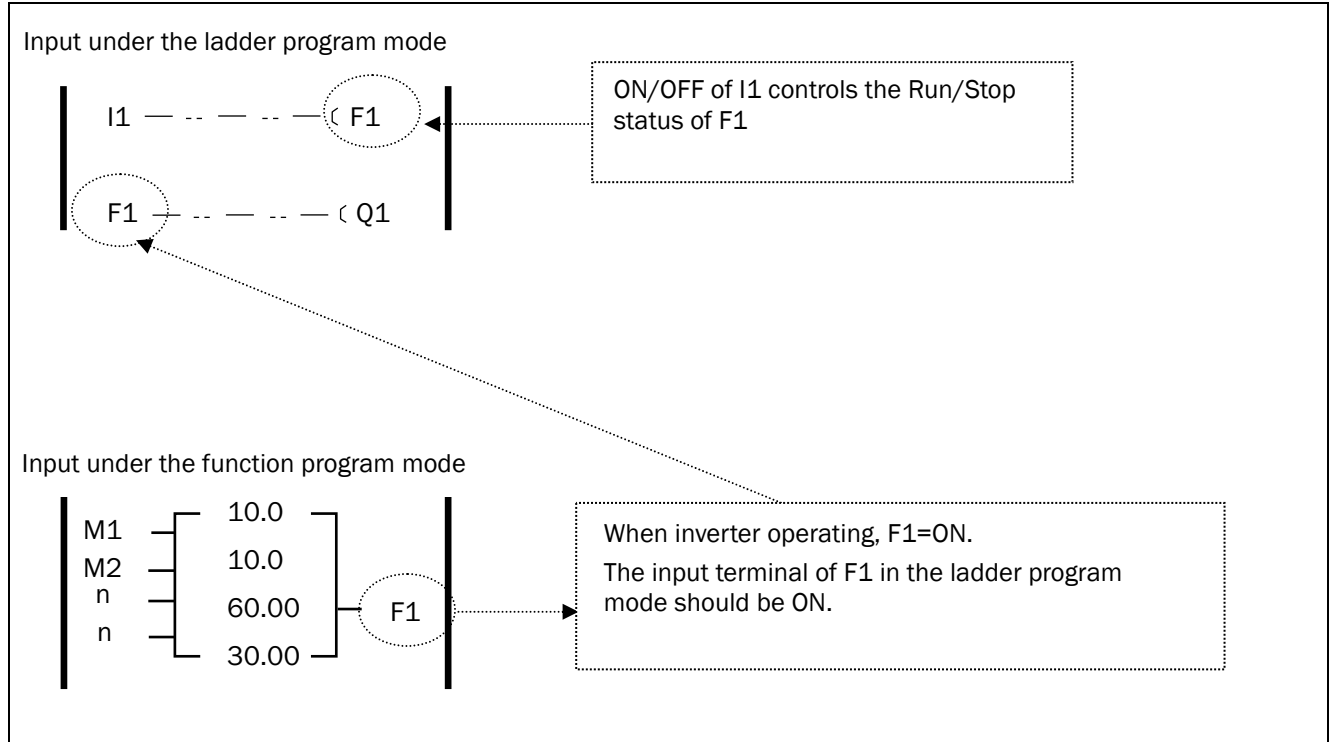

4. Troubleshooting and Maintenance

4.1 Error display and remedying errors

4.1.1 Errors which cannot be recovered manually

Display	Error	Cause	Remedy
CPF	Program problem	External noise interference	Connect a parallel RC burst absorber across the magnetizing coil of the magnetic contactor that causes interference
EPR	EEPROM problem	Faulty EEPROM	Replace EEPROM
-CV-	Voltage too high during stop	Detection circuit malfunction	Send the VSD back to be repaired
-LV-	Voltage too low during stop	<ol style="list-style-type: none"> 1. Power voltage too low 2. Restraining resistor or fuse burnt out. 3. Detection circuit malfunctions 	<ol style="list-style-type: none"> 1. Check if the power voltage was correct or not 2. Replace the restraining resistor or the fuse 3. Send the VSD back to be repaired
-OH-	The VSD is overheated during stop	<ol style="list-style-type: none"> 1. Detection circuit malfunctions 2. Ambient temperature too high or bad ventilation 	<ol style="list-style-type: none"> 1. Send the VSD back to be repaired 2. Improve ventilation conditions
CTER	Current Sensor detecting error	Current sensor error or circuit malfunction	Send the VSD back to be repaired

Note @ the failure contact does not function.

4.1.2 Errors which can be recovered manually and automatically

Display	Error	Cause	Remedy
OC-S	Over-current at start	<p>The motor wind and enclosure short circuit</p> <p>The motor contacts and earth short circuit</p> <p>The IGBT module is damaged</p>	<p>Inspect the motor</p> <p>Inspect the wire</p> <p>Replace the transistor module</p>
OC-D	Over-current at deceleration	The preset deceleration time is too short	Set a longer deceleration time
OC-A	Over-current at acceleration	<ol style="list-style-type: none"> 1. Acceleration time too short 2. The capacity of the motor higher than the capacity of the VSD 3. Short circuit between the motor coil and the shell 4. Short circuit between motor wiring and earth 5. IGBT module is damaged 	<ol style="list-style-type: none"> 1. Set a longer acceleration time 2. Replace a VSD with the same capacity as that of the motor 3. Check the motor 4. Check the wiring 5. Replace the IGBT module

OC-C	Over-current at fixed speed	1. Transient load change 2. Transient power change	1. Increase the capacity of the VSD 2. Rerun parameter autotuning (0-06=1) 3. Reduce stator resistance (14-0) if the above remedies are helpless
OV-C	Voltage too high during operation/deceleration	1. Deceleration time setting too short or large load inertia 2. Power voltage varies widely	1. Set a longer deceleration time 2. Add a brake resistor or brake module 3. Add a reactor at the power input side 4. Increase VSD capacity
Err4	Illegal interrupt of CPU	Outside noise interference	Send back to be repaired if it happens repeatedly
OVSP	Over speed during operation	Motor load too great or VSD capacity too small Mother parameter error (vector mode) The gain is too great during vector mode operation The current detect circuit is faulty	1. Increase acceleration / deceleration time (3-02/3-03) 2. Input correct motor Parameter 3. Change stator Resistance gain and Rotor resistance gain (14-0/14-1). Recommended decrease 50~100, until 0 4. Send back to Emotron

4.1.3 Errors which can be recovered manually but not automatically

Display	Error	Cause	Remedy
OC	Over-current during stop	1. Detection circuit malfunction 2. Bad connection for CT signal cable	1. Check the noise between Power line and motor line 2. Send the VSD back to be repaired
OL1	Motor overload	1. Heavy load 2. Inappropriate settings of 0-02, 9-08~11	1. Increase the motor capacity 2. Set 0-02, 9-08~11 properly
OL2	VSD overload	Heavy load	Increase the VSD capacity
OL3	Over torque	1. Heavy load 2. Insufficient settings of 9-14, 9-15	1. Increase the VSD capacity 2. Set 9-14, 9-15 properly
LV-C	Voltage too low during operation	Power voltage too low 2. Power voltage varies widely	Improve power quality or increase the value of 2-01 Set a longer acceleration time Increase VSD capacitor Add a reactor at the power input side
OH-C	Heatsink temperature too high during operation	1. Heavy load 2. Ambient temperature too high or bad ventilation	1. Check if there are any problems with the load 2. Increase VSD capacity 3. Improve ventilation conditions

4.1.4 Special conditions

Display	Error	Description
STP0	Zero speed stop	Happens when preset frequency <0.1Hz
STP1	Fail to start directly	<ol style="list-style-type: none"> 1. If the VSD is set to external terminal control mode (1-00=1) and direct start is disabled (2-04=0001), the VSD cannot be started and will flash STP1 when the operation switch is turned to ON after applying power (refer to descriptions for 2-04). 2. Direct start is possible when 2-04=0001.
STP2	Keypad emergency stop	<ol style="list-style-type: none"> 1. If the VSD is set to external control mode (1-00=0001) and Stop key is enabled (1-03=0000), the VSD will stop according to the setting of 1-05 when the Stop key is pressed. STP2 flashes after stop. Turn the operation switch to OFF and then ON again to restart the VSD. 2. If the VSD is in communication mode and the Stop key is enabled (1-03=0000), the VSD will stop in the way set by 1-05 when the Stop key is pressed during operation and then flashes STP2. The PC has to send a Stop command then a Run command to the VSD for it to be restarted. 3. The Stop key cannot perform emergency stop when 1-03=0001
E.S.	External emergency stop	The VSD will ramp stop and then flash E.S., when it receives external emergency stop signal via the multifunctional input terminal (refer to descriptions of 5-00~5-06).
b.b.	External base block	The VSD stops immediately and then flashes b.b., when external base block is input through the multifunctional input terminal (refer to descriptions of 5-00~5-06).
ATER	Autotuning faults	<ol style="list-style-type: none"> 1. Motor data error resulting in for autotuning failure 2. Stops the VSD during Autotuning
PDER	PID feedback loss	PID feedback loss detect

4.1.5 Operation errors

Display	Error	Cause	Remedy
LOC	Parameter and frequency reverse already locked	<ol style="list-style-type: none"> Attempt to modify frequency /parameter while 3-17>0000 Attempt to reverse while 1-02=0001 	<ol style="list-style-type: none"> Set 3-17=0000 Set 1-02=0000
Err1	Key operation error	<ol style="list-style-type: none"> Press + or - while 1-06>0 or running at pre-set speed. Attempt to modify the parameter cannot be modified during operation (refer to the parameter list). 	<ol style="list-style-type: none"> The + or - is available for modifying the parameter only when 1-06=0 Modify the parameter during STOP
Err2	Parameter setting error	<ol style="list-style-type: none"> 3-01 in the range of 3-13 ± 3-16 or 3-14 ± 3-16 or 3-15 ± 3-16 3-003-01 The setting error as per performing autotuning (e.g. 1-00 = 0, 1-06=0) 	<ol style="list-style-type: none"> Modify 3-13~3-15 or 3-16 3-00>3-01 Set 1-00=0, 1-06=0 during autotuning
Err5	Modification of parameter is not available in communication	<ol style="list-style-type: none"> Issue a control command during communication disabled Modify the function 13-1~13-4 during communication 	<ol style="list-style-type: none"> Issue enable command before communication Set the specific parameter of the function before communication
Err6	Communication failed	<ol style="list-style-type: none"> Wiring error Communication parameter setting error Sum-check error Incorrect communication protocol 	<ol style="list-style-type: none"> Check hardware and wiring Check functions 13-1~13-4
Err7	Parameter conflict	Attempt to modify the function 15-0 or 15-7 Voltage and current detection circuit is abnormal	If Reset VSD is not available, please send the VSD back to be repaired
Err8	Factory setting error	When PLC is running, perform factory setting	Please perform factory setting before PLC stops.
EPr1	Parameter setting error copy unit failed	<ol style="list-style-type: none"> Set 3-18=1.2 without connecting copy unit. Copy unit failed 	<ol style="list-style-type: none"> Modify 3-18 Replace copy unit
EPr2	Parameter does not match	Copy the parameter to VSD to verify the parameter does not match.	<ol style="list-style-type: none"> Rewrite again Replace copy unit

4.2 General troubleshooting

Status	Checking point	Remedy
Motor cannot run	Is power applied to L1, L2, and L3 terminals (is the charging indicator lit)?	Is the power applied? Turn the power OFF and then ON again. Make sure the power voltage is correct. Make sure screws are secured firmly.
	Is there voltage across the output terminals T1, T2, and T3?	Turn the power OFF and then ON again.
	Is overload causing the motor to be blocked?	Reduce the load to let the motor run.
	Are there any abnormalities in the VSD?	See error descriptions to check wiring and correct if necessary.
	Has a forward or reverse running command been issued?	
	Has analogue frequency signal been entered?	Is analogue frequency input signal wiring correct? Is voltage of frequency input correct?
	Is operation mode setting correct?	Carry out operations via the digital panel.
Motor runs inversely	Is wiring for output terminals T1, T2, and T3 correct?	Wiring must match the motor's U, V, and W terminals.
	Is wiring for forward and reverse signals correct?	If necessary, check wiring is correct.
The motor speed cannot be regulated.	Is wiring for analogue frequency inputs correct?	If necessary, check wiring is correct.
	Is the operation mode correctly set?	Check the operation mode of the operator.
	Is the load too heavy?	Reduce the load.
Motor running speed too high or too low	Are the motor specifications (poles, voltage...) correct?	Confirm the motor's specifications.
	Is the gear ratio correct?	Confirm the gear ratio.
	Is the setting of the highest output frequency correct?	Confirm the highest output frequency.
Motor speed varies unusually	Is the load too heavy?	Reduce the load.
	Does the load vary largely?	Minimize the variation of the load. Increase capacities of the VSD and the motor.
	Is the input power lack of phase?	Add an AC reactor at the power input side if using single-phase power. Check wiring if using three-phase power.

4.3 Quick troubleshooting of VSC

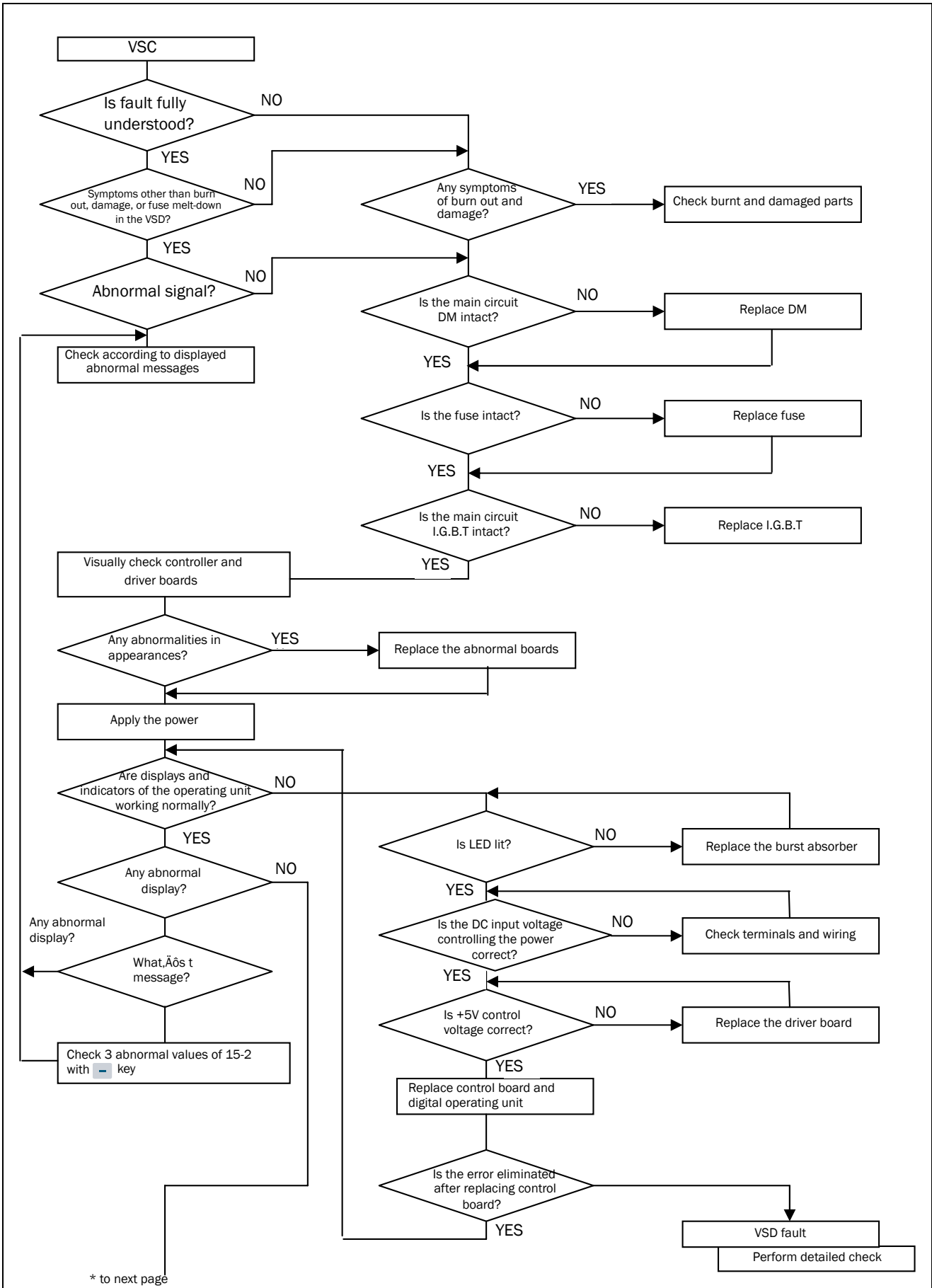

* to next page

* to previous page

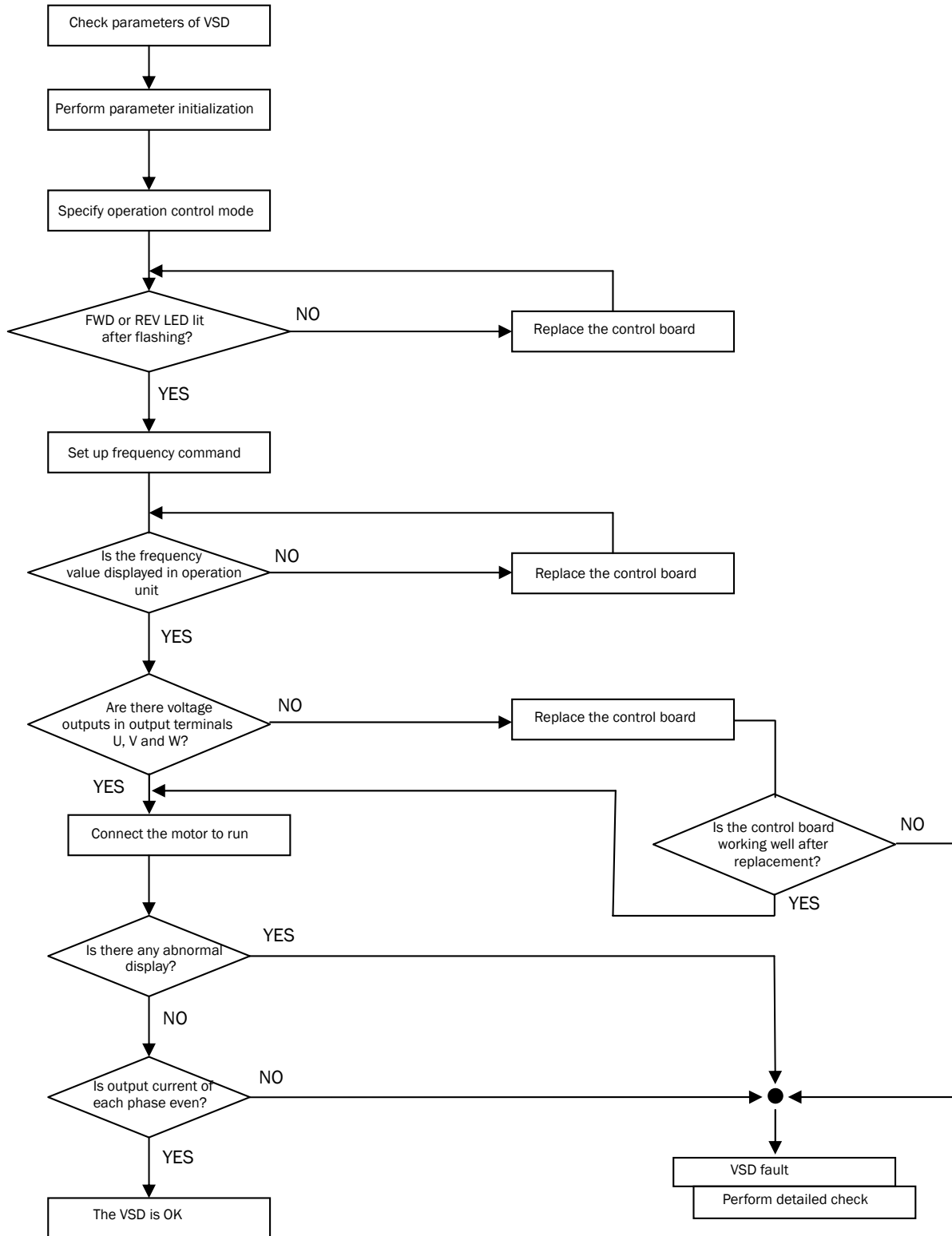

Troubleshooting for OC, OL error displays

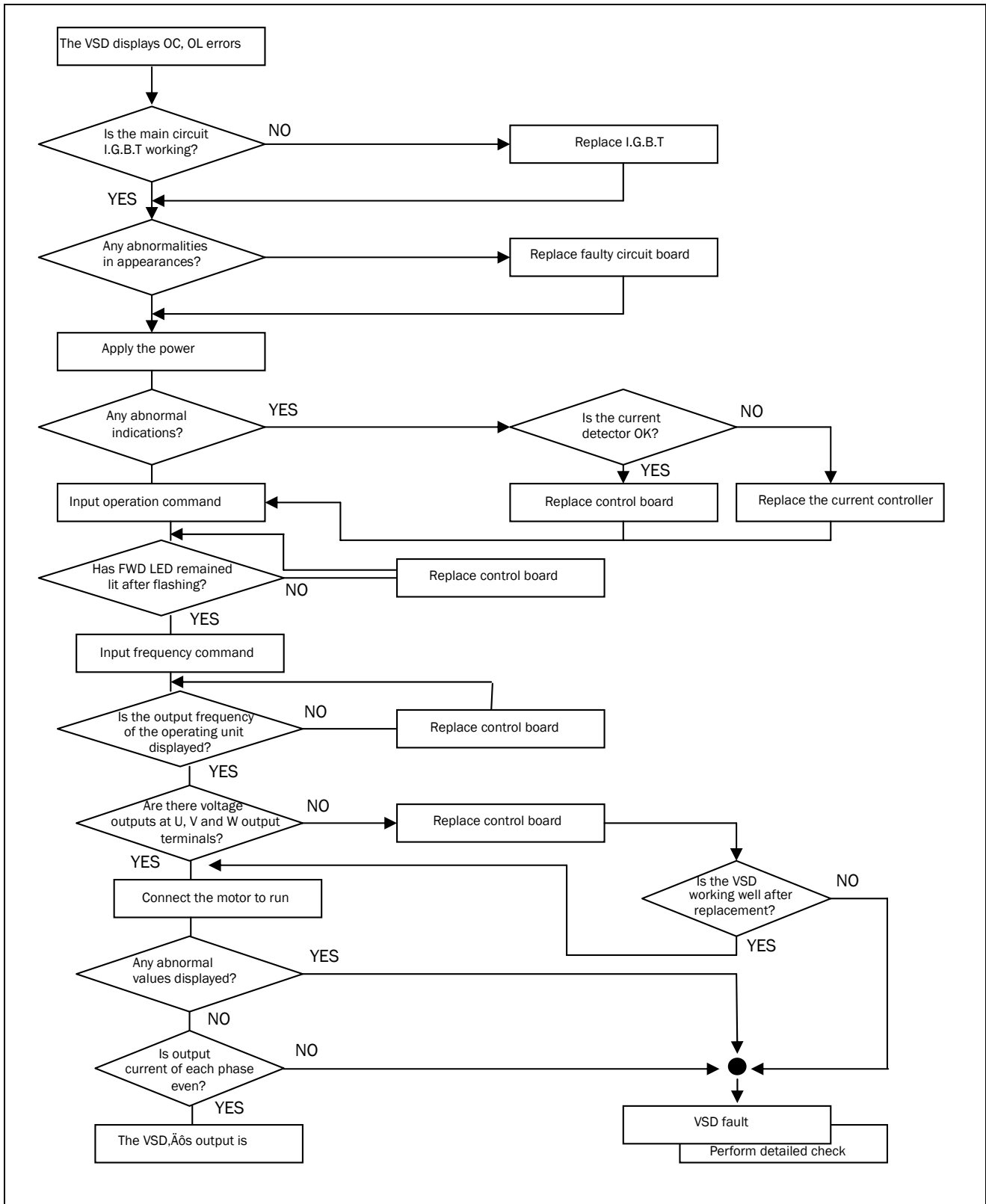

Troubleshooting for OV, LV error

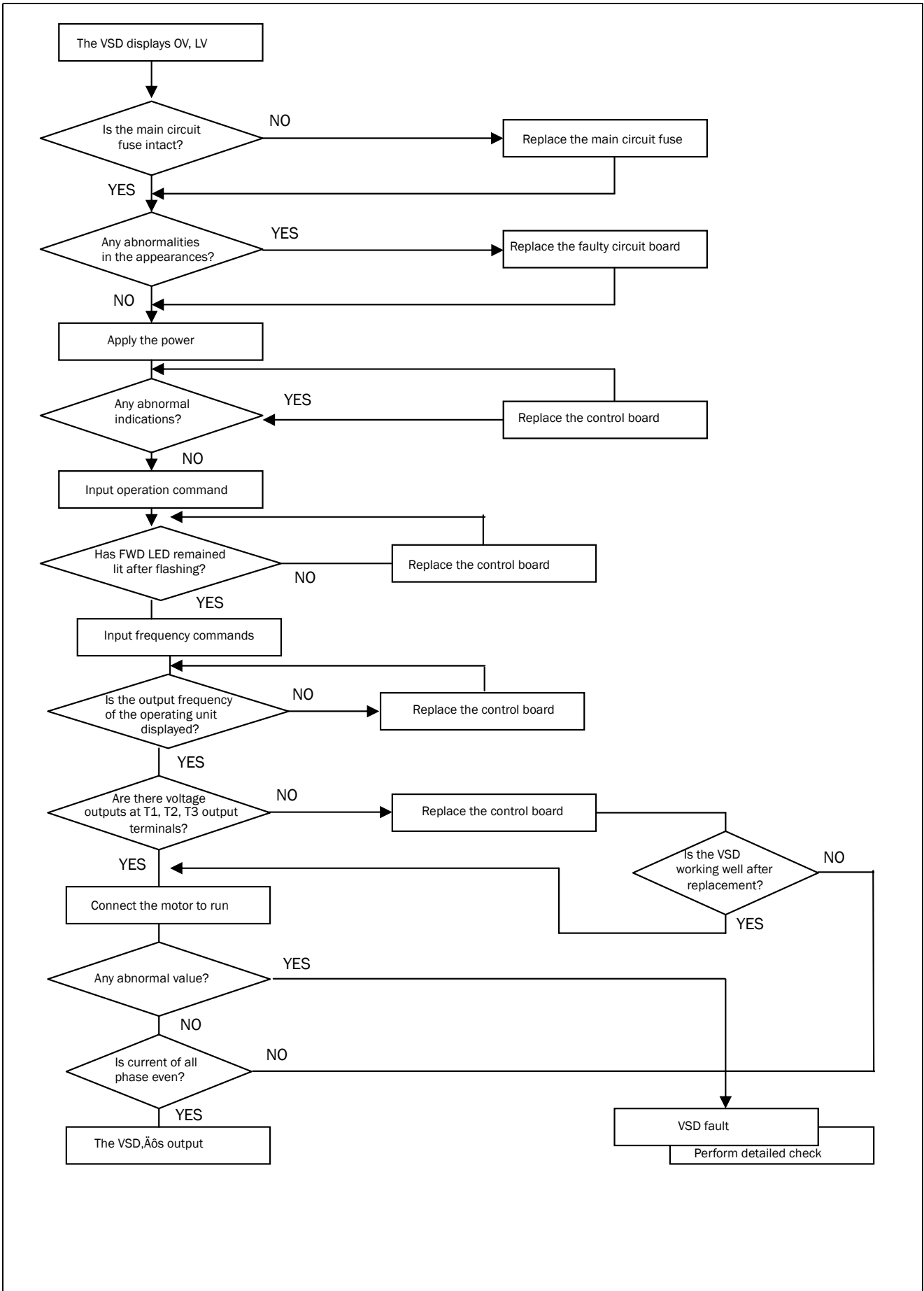

The motor cannot run

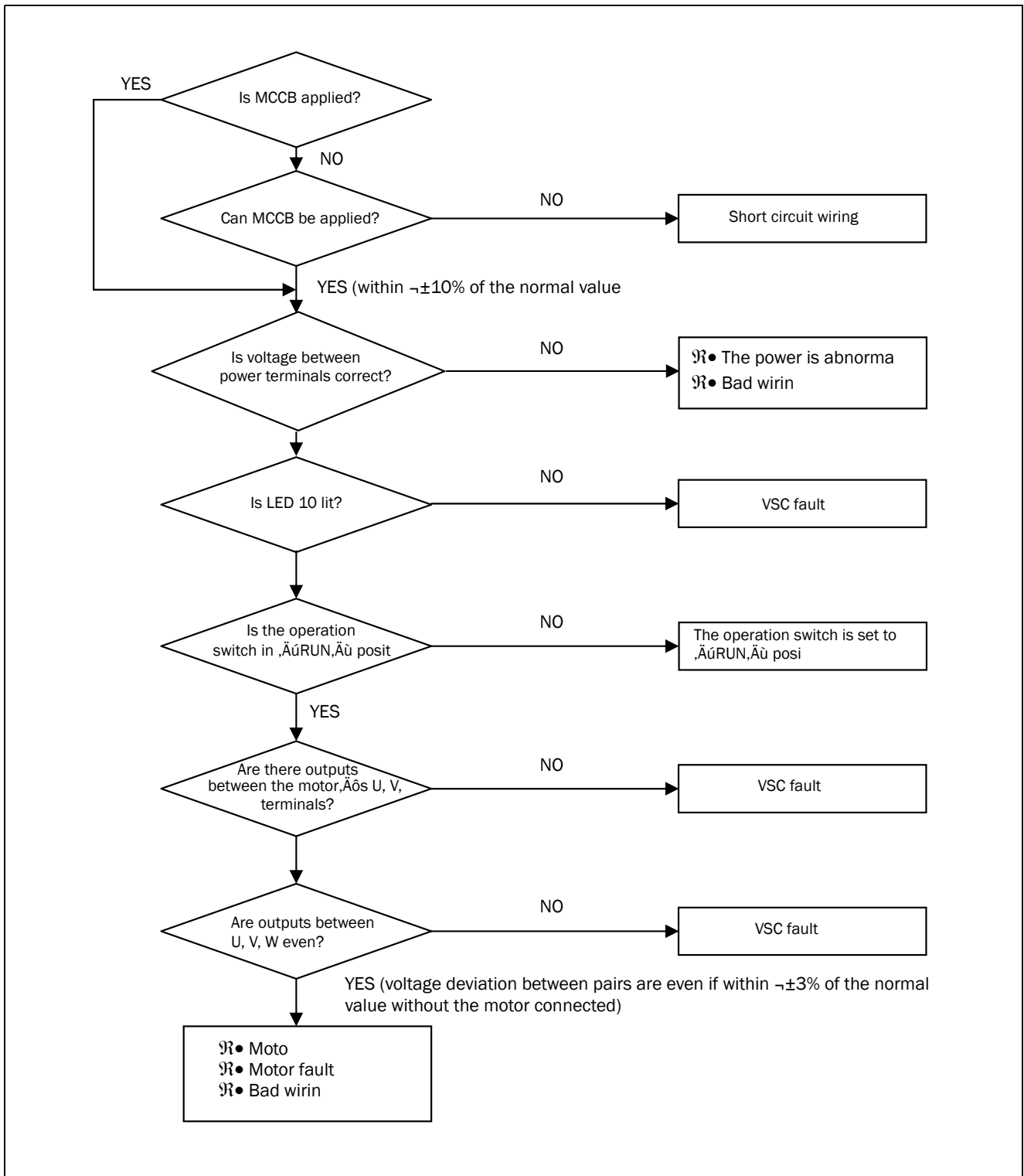

The motor is overheated

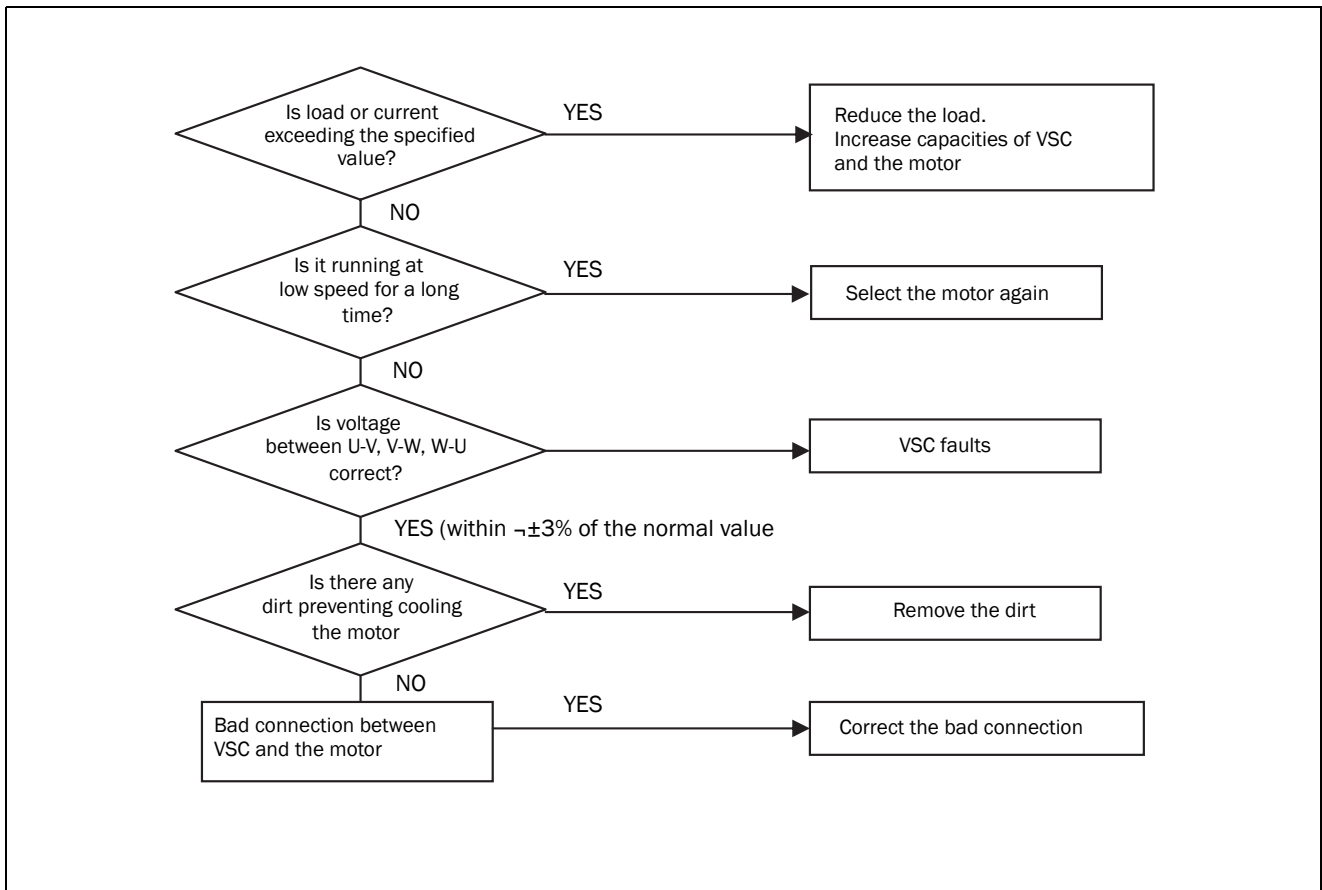

Motor runs unevenly

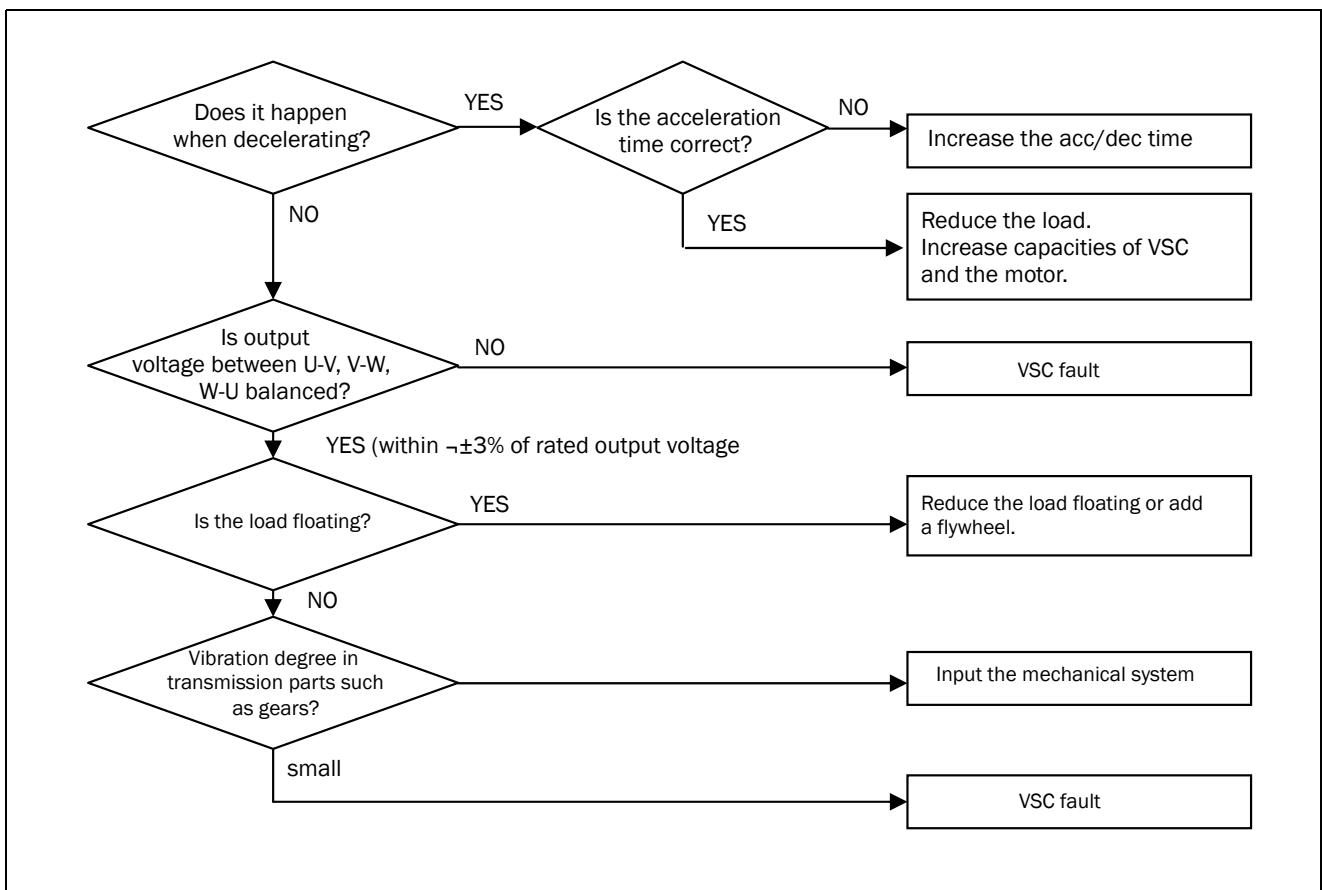

4.4 Routine inspection and periodical inspection

To ensure stable and safe operations, check and maintain the VSD regularly and periodically.

The table below lists the items to be checked to ensure stable and safe operations.

Check these items 5 minutes after the “Charge” indicator goes out to prevent service personnel from being injured by residual electric power.

Items	Details	Checking period		Methods	Criteria	Remedies
		Daily	Annually			
Ambient conditions around the machine	Confirm the temperature and humidity around the machine	<input type="radio"/>		Measure with thermometer and hygrometer according to installation notices.	Temperature: -10 to 40°C Humidity: Below 95% RH	Improve the circumstances
	Are there inflammable piled up around?	<input type="radio"/>		Visual check	No foreign matters	
Installation and grounding of the VSD	Any unusual vibration from the machine	<input type="radio"/>		Visual, hearing	No foreign matters	Secure screws
	Is the grounding resistance correct?		<input type="radio"/>	Measure the resistance with a multi-tester	200V series: below 100 400V series: below 10	Improve the grounding
Input power voltage	Is the voltage of the main circuit correct?	<input type="radio"/>		Measure the voltage with a multi-tester	Voltage must conform to the specifications	Improve input voltage
External terminals and internal mounting screws of the VSD	Are secure parts loose?		<input type="radio"/>	Visual check Check with a screwdriver	No abnormalities	Secure or send back for repair
	Is the terminal base damaged?		<input type="radio"/>			
	Obvious rust stains		<input type="radio"/>			
Internal wiring of the VSD	Deformed or crooked		<input type="radio"/>	Visual check	No abnormalities	Replace or send back for repair
	Any damage of the wrapping of the conducting wire		<input type="radio"/>			
Heat sink	Heap of dust or mingled trifles	<input type="radio"/>		Visual check	No abnormalities	Clean up heaped dust
Printed circuit board	Heap of conductive metal or oil sludge		<input type="radio"/>	Visual check	No abnormalities	Clean up or replace the circuit board
	Discoloured, overheated, or burned parts		<input type="radio"/>			
Cooling fan	Unusual vibration and noise		<input type="radio"/>	Visual or hearing check	No abnormalities	Replace the cooling fan
	Heap of dust or mingled trifles	<input type="radio"/>		Visual check		Clean up
Power component	Heap of dust or mingled trifles		<input type="radio"/>	Visual check	No abnormalities	Clean up
	Check resistance between each terminals		<input type="radio"/>	Measure with a multi-tester	No short circuit or broken circuit in three-phase output	Replace power component or VSD
Capacitor	Any unusual odour or leakage	<input type="radio"/>		Visual check	No abnormalities	Replace capacitor or VSD
	Any inflation or protrusion	<input type="radio"/>				

4.5 Maintenance and inspection

The VSD does not require daily inspection and maintenance.

To ensure long-term reliability, follow the instructions below when performing regular inspection. Turn the power off and wait for the charge indicator (LED101) to go out before inspection to avoid receiving an electric shock possibly caused by charges resides in high-capacity capacitors.

- (1) Clean up the accumulation of muck inside the VSD.
- (2) Check if there are any loose terminal screws and securing screws. Tighten all loose screws.

(3) Insulation tests

(a) Disconnect all leads connecting T-VERTER to the external circuit when performing insulation tests against external circuit.

(b) An internal insulation test should only be performed against the main circuit of the T-VERTER body. Use a high resistance DC 500V meter with insulating resistance higher than 5M.

Caution: Do not perform this test against the control circuit.

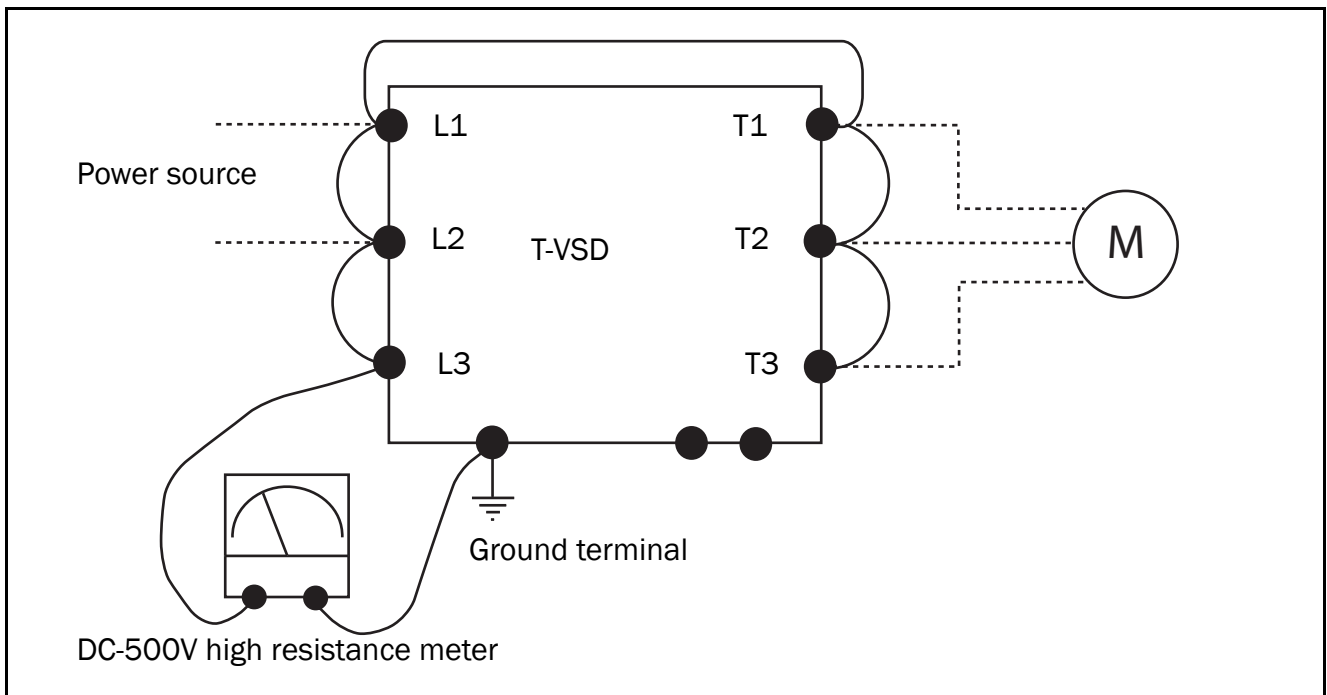

5. Peripheral Components

5.1 Reactor specification for input side

Model		AC inductance on input side	
		Current (A)	Inductance (mH)
VSC48-	009	10.0	2.2
	013	15.0	1.42
	018	20.0	1.06

5.2 Reactor specification on DC side

Model		DC inductance for input side	
		Current (A)	Inductance (mH)
VSC48-	VSC48-009	8.8	3.98
	VSC48-013	13	2.69
	VSC48-018	17.5	2.00

5.3 Braking unit and braking resistor

VSC series braking current calculation

VSD Model	Braking Unit		Braking Resistor per braking unit	Suitable Motor Capacity (HP)	Suitable Motor Capacity (KW)	Braking resistor Specification		Braking resistor ED(%)	Braking torque (%)	Resistor dimension (L*W*H) mm
	Model	Number used				Type	(W)			
VSC48-009	-	-	JNBR-400W150-	5	3.7	400	150	10	126	395*34*78
VSC48-013	-	-	JNBR-600W130-	7.5	5.5	600	130	10	102	470*50*100
VSC48-018	-	-	JNBR-800W100	10	7.5	800	100	10	99	535*50*110

Formula for braking resistor: $W = (V_{pnb} * I_{pnb}) * ED\% / R$

1. W: braking resistor consumption power
2. V_{pnb} : braking voltage (220V=380VDC, 440V=760VDC)
3. ED%: braking effective period
4. R: using braking resistor
5. Another choice: 0050-BE: (JNTBU-430 + JNBR-4R8KW32) x 2

0060-BE: (JNTBU-430 + JNBR-4R8KW27R2) x 2

Above 25HP, please add Braking Unit: 200V JNTBU-230

400V JNTBU-430

400V JNVPHV-0060

For detailed information, please contact your supplier.

5.4 EMC Filter

The VSD adopts rapid switching components to improve the efficiency of the motor and to reduce the motor noise. Using the EMC filter allows the EMI (Electromagnetic Interference) and RFI (Radio Frequency interference) to be controlled within a certain range.

EMC Directive

The VSD with built-in filter complies with the EMC Directive 89/336/EEC, limiting the environmental EMI and RFI. Independent tests have demonstrated compliance to the following standards when the optional filters are used.

EMI radio standard °BEMS immunity standard

EN 61800-3 1996/A11: 2000: First Environment Restricted Distribution

Filter Selection

VSD Model		Rating (INPUT)	Filter Model	
			First Environment Restricted Distribution	First Environment Unrestricted Distribution
VSC48	009	3 ϕ 323~528 V	Built-in	Contact supplier
	013	3 ϕ 323~528 V	Built-in	Contact supplier
	018	3 ϕ 323~528 V	Built-in	Contact supplier

5.5 Interface Card

5.5.1 RS-485 Interface Card (Model: JNSIF-485)

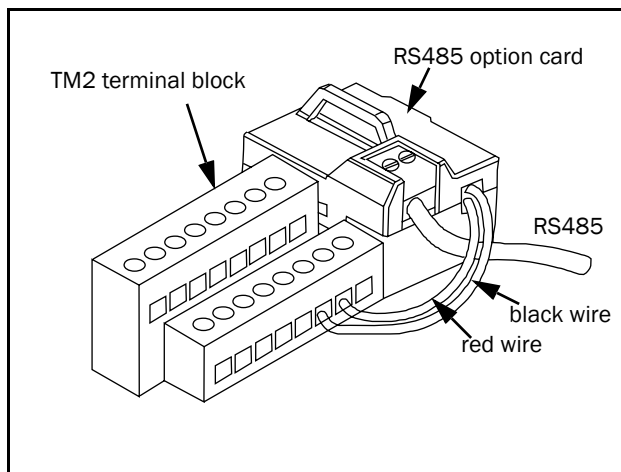

NOTE:

1. Connect the black wire to the "com" terminal of TM2.
2. Connect the red wire to the "24V" terminal of TM2.

JNSIF-485 Wiring Diagram:

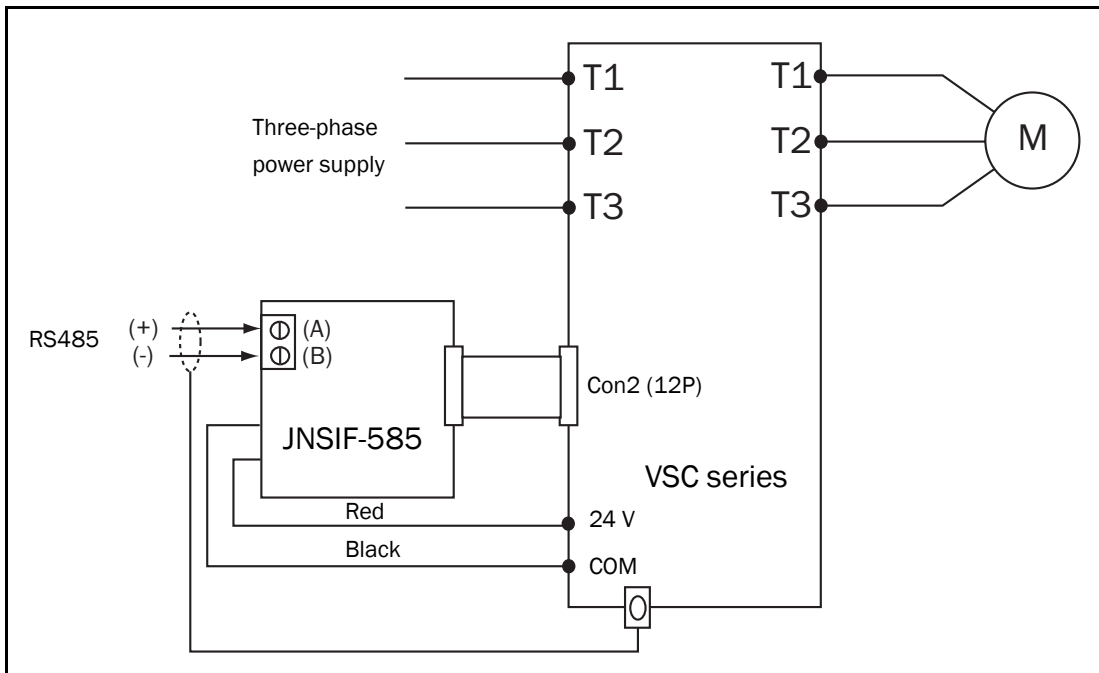

NOTE:

Please put on the VSD cover to avoid the Interface card being disturbed by outside static electricity.

Please use isolated RS232/RS485 converter to link PC and interface card to avoid damaging equipment.

5.5.2 RS-232 Interface Card (Model: JNSIF-232)

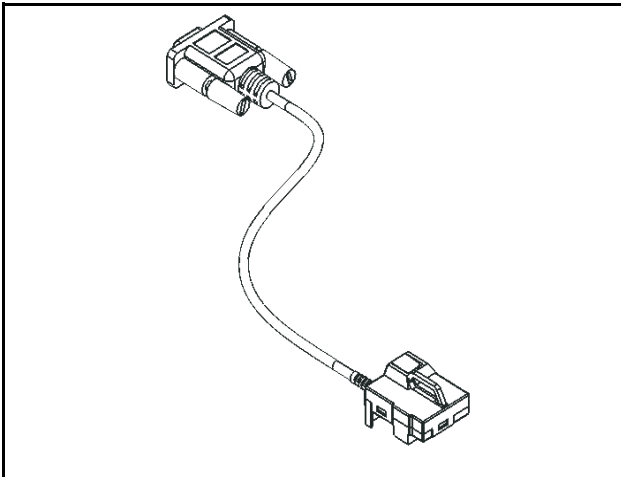

JNSIF-232 Wiring Diagram

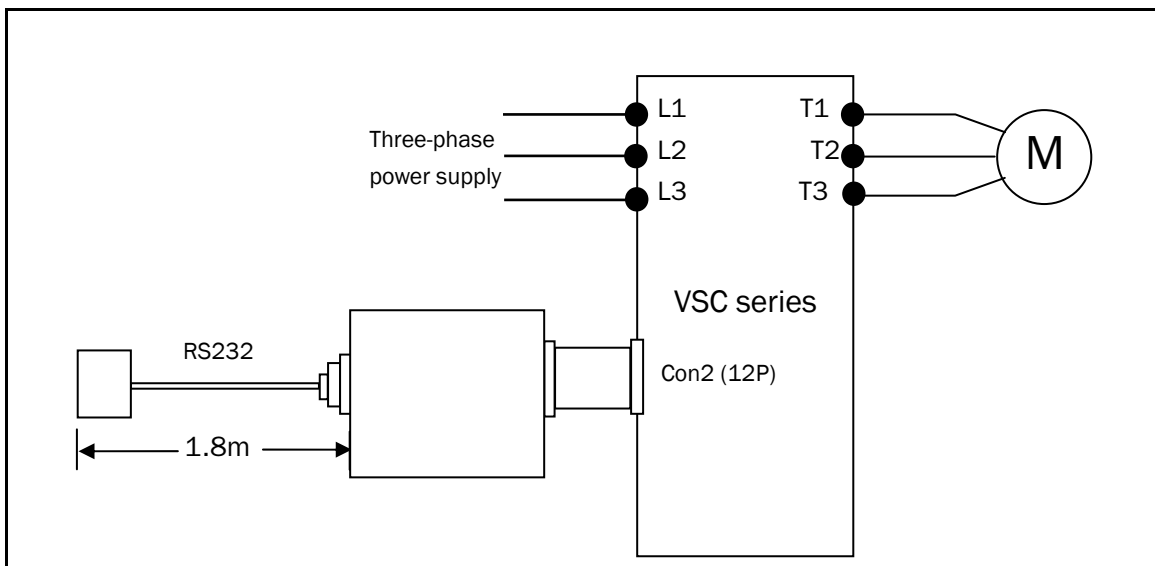

5.5.3 Program Copy Unit (Model: JNSIF-MP)

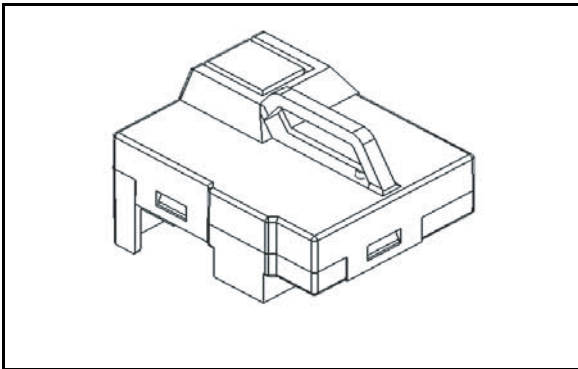

JNSIF-MP Wiring Diagram

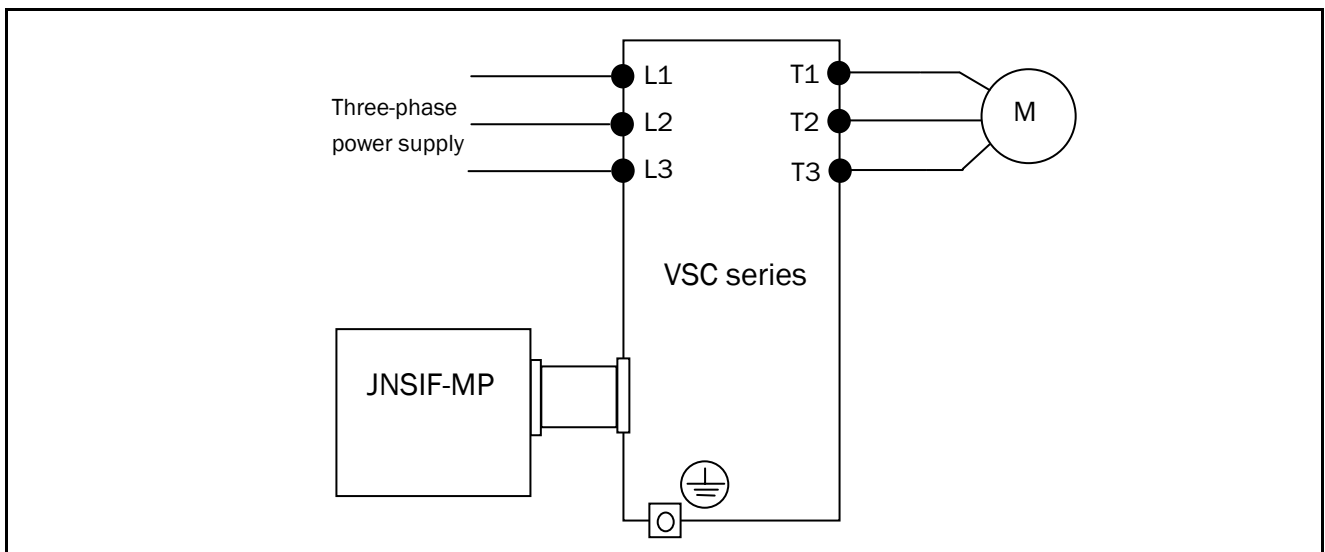

Appendix 1: List of internal parameters for VSC motor

Factory settings for the motor's internal parameters.

Parameter Model		14-0 (Stator Resistance)	14-1 (Rotor Resistance)	14-2 (Equivalent Inductance)	14-3 (Magnetization Current)	14-4 (Iron Loss Conductance)
VSC 48-	009	260	200	800	7200	0
	013	240	160			
	018	220	150			

NOTE: 1. The above parameters are idle in V/F Control Mode. These parameters can be enabled in vector control mode.

2. The motor parameters (14-0~14-4) cannot be modified when factory settings are in vector mode. The internal parameters will be maintained after autotuning (refer to Autotuning and Description of motor's internal parameters).

3: The motor parameters (14-0~14-4) will be completely modified to factory settings in any operation mode.

Appendix 2: VSC parameter setting list

Customer				VSD Model			
Using Site				Contact Phone			
Address							
Parameter Code	Setting Content	Parameter Code	Setting Content	Parameter Code	Setting Content	Parameter Code	Setting Content
0-00		3-14		6-06		10-7	
0-01		3-15		6-07		10-8	
0-02		3-16		6-08		10-9	
0-03		3-17		7-00		11-0	
0-04		3-18		7-01		11-1	
0-05		3-19		7-02		11-2	
0-06		3-20		7-03		11-3	
0-07		3-21		7-04		11-4	
0-08		3-22		7-05		11-5	
1-00		3-23		8-00		11-6	
1-01		3-24		8-01		11-7	
1-02		3-25		8-02		12-0	
1-03		3-26		8-03		12-1	
1-04		3-27		8-04		12-2	
1-05		3-28		8-05		12-3	
1-06		3-29		9-00		12-4	
1-07		4-00		9-01		12-5	
2-00		4-01		9-02		12-6	
2-01		4-02		9-03		13-0	
2-02		4-03		9-04		13-1	
2-03		4-04		9-05		13-2	
2-04		4-05		9-06		13-3	
2-05		5-00		9-07		13-4	
2-06		5-01		9-08		14-0	
3-00		5-02		9-09		14-1	
3-01		5-03		9-10		14-2	
3-02		5-04		9-11		14-3	
3-03		5-05		9-12		14-4	
3-04		5-06		9-13		15-0	
3-05		5-07		9-14		15-1	

3-06		5-08		9-15		15-2	
3-07		5-09		10-0		15-3	
3-08		6-00		10-1		15-4	
3-09		6-01		10-2		15-5	
3-10		6-02		10-3		15-6	
3-11		6-03		10-4			
3-12		6-04		10-5			
3-13		6-05		10-6			



DEDICATED DRIVE

Emotron AB, Mörsaregatan 12, SE-250 24 Helsingborg, Sweden

Tel: +46 42 16 99 00, Fax: +46 42 16 99 49

E-mail: info@emotron.se

Internet: www.emotron.com